

Structured Patient Data Encryption Solutions

Summary:

Developing an encryption solution to encrypt patient data or any PHI data in-transit and at rest. Encrypted data must be decrypted when the same user or other users retrieve encrypted data.

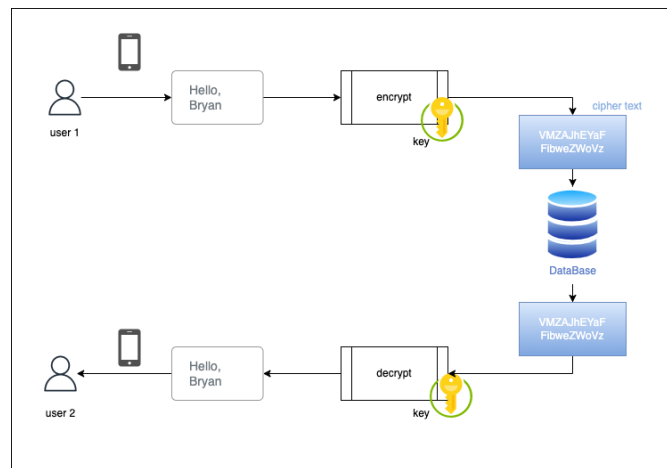

- Protected Health information (PHI) or Confidential Information such as a social security number, or biometric data, patient Id etc.
- Encrypt all or selected PHI data as illustrated in below table.

PID	FName	LName	SSN	Age	Gender	Phone	Email	Address	Photo ID
1	🔒	🔒	🔒	🔒	🔒	🔒	🔒	🔒	🔒
2	🔒	🔒	🔒	🔒	🔒	🔒	🔒	🔒	🔒
3	🔒	🔒	🔒	🔒	🔒	🔒	🔒	🔒	🔒
4	🔒	🔒	🔒	🔒	🔒	🔒	🔒	🔒	🔒
5	🔒	🔒	🔒	🔒	🔒	🔒	🔒	🔒	🔒
6	🔒	🔒	🔒	🔒	🔒	🔒	🔒	🔒	🔒
7	🔒	🔒	🔒	🔒	🔒	🔒	🔒	🔒	🔒

Sample patient data.

- Encrypt data in transmission either on on-premises or cloud using network encryption protocols, such as internet protocol security (IPsec) and transport layer security (TLS), to establish a secure connection between endpoints.

Product Description:

This data encryption solution must be developed as a product so that end-users can use the product to protect their data.

This solution must be platform agnostic, can be used by any health IT companies in the world to encrypt their patient or any other data of their choice. This solution must be a SaaS product, also support multi-tenant healthcare cloud platforms, as well as private cloud or on-premises health IT solutions.

The end-user of this solution must be able to select the data needed to be encrypted in a configure file or masters.

Value Add:

Patient data is usually shared via emails, having this encryption solution extended to email and/or files attached in the email adds more value to the solution.

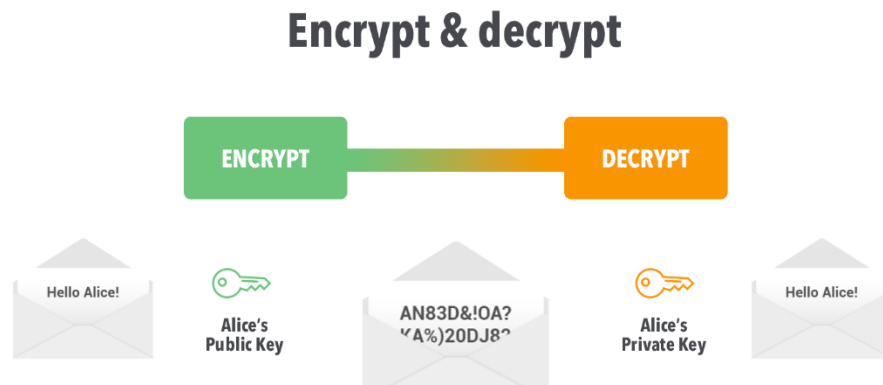

Post-development Steps and Cost.

Below tasks must be completed before we go to the market.

1. Performance test: before and after encryption solution is implemented.
2. International patent
3. VAPT (approximate cost Rs 5 lakhs)
4. GDBR Compliant (approximate cost Rs 5 lakhs)
5. Become a partner with Microsoft, Google, Sales Force to list the product at their marketplace.