

./ADASTRA

Adastra App / Infra Modernization Overview

Unlock Your Cloud Potential through Adastra's
Azure Modernization Assessment Package

Kevin Harmer

./ADASTRA

Adastra Overview



Solutions & Service

MODERN ARCHITECTURE

Enterprise Architecture
Cloud Architecture
Cloud Computing
Data Lake
Data Engineering
Managed Services

DATA MANAGEMENT

Data Governance
Data Quality
Master Data Mgmt
Reference Data Mgmt
Meta Data Mgmt
Data Lineage
Privacy & Security
Cybersecurity

ANALYTICS

Business Intelligence
Visualization
Machine Learning
Artificial Intelligence
Natural Language Processing
RPA & IPA
Simulation & Optimization

APPLICATION DEVELOPMENT

Software Factory
Mobile Apps
UX/UI
Solution Development

Adastra delivers **industry-leading** solutions & services across the **data & digital** spectrum.

Adastra's Global Presence



 Adastra Offices

 **CANADA**

Toronto
Calgary
Ottawa
Vancouver
Montreal

 **UNITED STATES**

Los Angeles
Miami
New York

 **AUSTRIA/
SLOVAKIA**

Bratislava

 **CZECH REPUBLIC**

Prague

 **GERMANY**

Frankfurt
Wolfsburg
Hanover
Munich
Magdeburg
Darmstadt

 **BULGARIA**

Sofia
Varna
Plovdiv

 **GREECE**

Thessaloniki

 **THAILAND**

Bangkok
Chiang Mai

 Countries where we have delivered projects



8

Countries



22

Offices



500+

Customers



2,200+

Professionals



40+

Countries where we
have delivered projects



20+

Languages
supported

ADASTRA'S Superpowers

Data is the heartbeat of every organization - it brings strategy to life and enables great customer experiences.

For over 20 years, Adastra has been driving our customers forward leveraging Data & AI as a guiding light and business enabler.

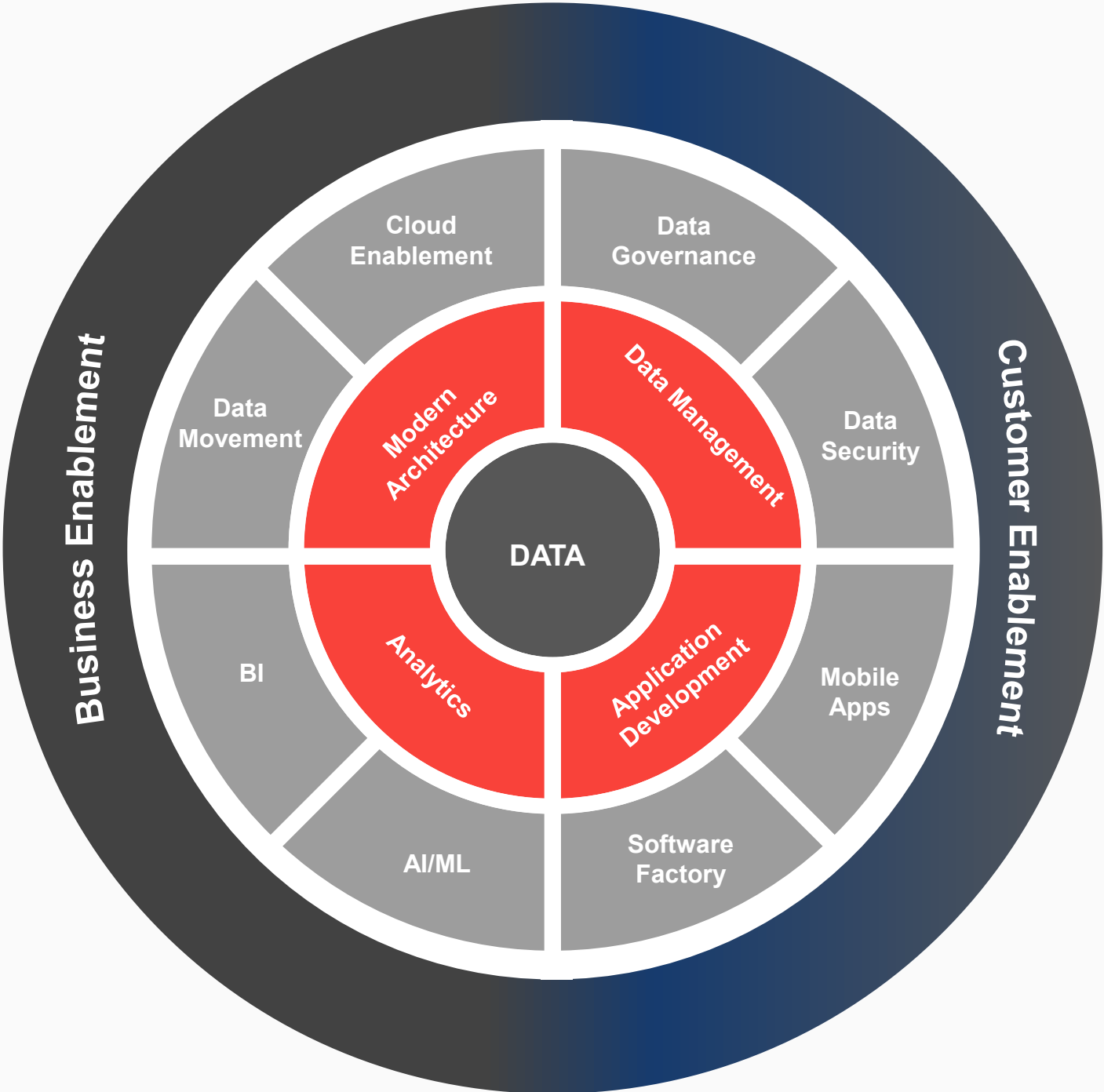

Adastra: #1 Data / AI Partner

Microsoft Impact Awards Won: Analytics, AI, Data Platform Modernization, Financial Services, Manufacturing, Commercial
Microsoft Impact Awards Runner-Up: Partner of the Year, Global Analytics, Global Power BI, Migration, Customer Journey

Ability to Scale

With over 2500 GLOBAL staff, 500 CDN staff, and 500 Azure and Power Platform specialists, Adastra is ready to scale

Proven Success

Adastra has the best record in Canada, successfully driving customer Azure adoption / ROI for over 200 organizations in the last two years

Best Shore Delivery

Adastra's best shore delivery model ensures top global experts can be applied to any project and provides offshore economies of scale for heavy lift tasks, with global teams working in partnership with our on-location experts.
Adastra offers global 24 / 7 delivery and support, through our NA, EUR, and ASIA teams.

Complete Stack Delivery

Azure Infrastructure, Azure App Dev, Azure BizApps (O365 / D365), Azure BI Analytics, Azure Big Data, Azure Data Science, and Power Platform

Agility

Adastra delivers for customers of all sizes: from SMC to Enterprise



Adastra's Deep Microsoft Partnership



Data & AI
Azure

Specialist
Windows Server and SQL Server
Migration
Analytics



Infrastructure
Azure

Specialist
Windows Server and SQL Server
Migration



Digital & App Innovation
Azure

Specialist
Low Code Application
Development



Business Applications

Specialist
Low Code Application
Development

Adastra: Go-To Partner for Data & AI

- 10x Impact Award Winner
- 12x Impact Award Runner-Up
- 2x Global Impact Award Runner-Up

- Advanced Specialization for Azure Analytics
- Advanced Specialization for Azure Migration
- Azure Migration Factory Partner

- Microsoft Fabric 50 Partner
- Product Team Collaboration Partner across Fabric / Databricks / Synapse / Purview products



Adastra Azure Specializations

AZURE FOUNDATION

cloud adoption framework, well architected framework, tenant design, resource naming, service tag approach, network architecture, governance design, tco analysis, hybrid network implementation, devops integration, azure foundation implementation, iac automation, ...

AZURE APP / MIGRATION

app / data assessment, app / data decisioning (lift / shift vs modernize), app / data architecture, api architecture, microservices architecture, app/ data security design, migration roadmap, migration execution, iac pipelines, devops integration, ...

AZURE SECURITY

security assessment, identity strategy, role based access, secrets management, encryption, data loss protection, api management, private zone configuration, siem / soar integration, policy enforcement, security implementation ...

AZURE ANALYTICS

analytics assessment, analytics architecture, analytics roadmap, data zoning, enterprise model design (kimball, inmon, data vault), ETL data pipelines, persona enablement, citizen report development, trusted data as a service, ...

AZURE BIG DATA

big data assessment, data lake design, Hadoop integration, PySpark data engineering, ELT pipelines, spark delta lake, spark streaming, serverless compute, devops integration, ...

AZURE AI / ML

advanced analytics assessment, cognitive service integration, r&d model training / testing, ml ops implementation, ai / ml pipelines, data science workbench automation, devops integration, ...

POWER PLATFORM

citizen development assessment, power platform governance, roles / responsibilities, environment strategy, CoE kit, canvas / model apps, power automate flows, power automate rpa, power platform dataverse, power bi datasets / reports, ...

AZURE DATA GOVERNANCE

data governance assessment, data catalog, data classification, data sensitivity, data use governance, data privacy, data lineage, master data management, data quality management, reference data management, ...

AZURE INTEGRATION PAAS

integration paas assessment, api management, logic workflows, service bus management, event grid distribution, peer to peer patterns, pubsub patterns, managed file transfers, iot telemetry streaming, iot edge device management, ...

Adastra Canada's Growing Azure Team

250 Azure Specialists
(200 Data, 50 App/Infra)

35 Azure Architects
(25 Data, 10 App/Infra)

**50 Azure
Data Scientists**

**150 Azure Certified
Resources**

**100 Power BI
Developers**

**50 Power App / Automate
Developers**

50% in Canada, 50% in Europe / Asia



Realize Your Data-Driven Destiny

For 20+ years, customers have trusted Adastra to design and deliver comprehensive data-driven solutions that fuel efficiency, innovation and long-term success. Our diverse set of Superpowers transform the way organizations utilize their data, unlocking its full potential.



Adastra Managed Services

Engage & Onboard



Needs Discovery



Service Design



Service Transition

Run & Operate



Incident Management



24/7 Support



Monitoring



Cloud Hosting

Manage & Control



Service Management



Cost Management & Optimization



Identity & Access Management



Provisioning & Change Management



Governance & Compliance

Adastra as your Digital Partner as a Service offers you enterprise-grade analytics capabilities, effective cost management, and accelerated time to market

Impact at Customers



400% Business Growth Facilitated by an Azure Cloud Migration at large logistics company

- 8x** faster system integration
- 400%** business growth facilitated
- 140** virtual machines migrated to Azure



70% improvement in data acquisition speed using Lucid and GenAI for Microsoft Fabric Modernization.

- Processed **1.3TB** of POS transaction data from the last 2.5 years.
- Over **2 billion** item transactions over 190 supermarkets.
- 400x** reduction in turn-around time for POS data onboarding
- 20x** increase in development speed.
- 10x** cost savings.



Manufacturing process optimization decreased CO2 emissions and shipment costs by 20%

- 20%** decrease in shipment costs
- 20%** lower CO2 emissions

Accelerate Azure Success with Aداstra

Partner With Aداstra Through One of Three Options

Cloud Solution Provider (new Subscription) or Digital Partner of Record / Partner Admin Link (existing Subscription)

Through Aداstra Partnership

1. Achieve greater ROI from your Azure investments
2. Effectively leverage and integrate new Azure service offerings
3. Gain a trusted partner to guide you through your Azure journey
4. Implement the right fit-for-purpose service architecture
5. Achieve optimal performance at a manageable cost

Choose the right partnership option at **no additional cost!**

BENEFITS	CSP	DPO R	PA L
Service Planning and Coaching	✓	✓	✓
Service Design	✓	✓	
Cost Advisement	✓	✓	
Cost Management / Alerting	✓		
Service Monitoring / Alerting	✓		
Service Automation	✓		
Help Desk Support	✓		
Service Provisioning	✓		
Aداstra Service Credits	✓	✓	✓



./ADA STRA

Adastra Azure App Modernization Approach



Drive Differentiating Change

Successful cloud modernization requires organizations create awareness, build a compelling case for change, engage stakeholders, and establish end user readiness.

Adastra's Organizational Change Management (OCM) methodology is founded on key principles, developed through best practice research, practical, on the ground application in a range of environments and maturity level

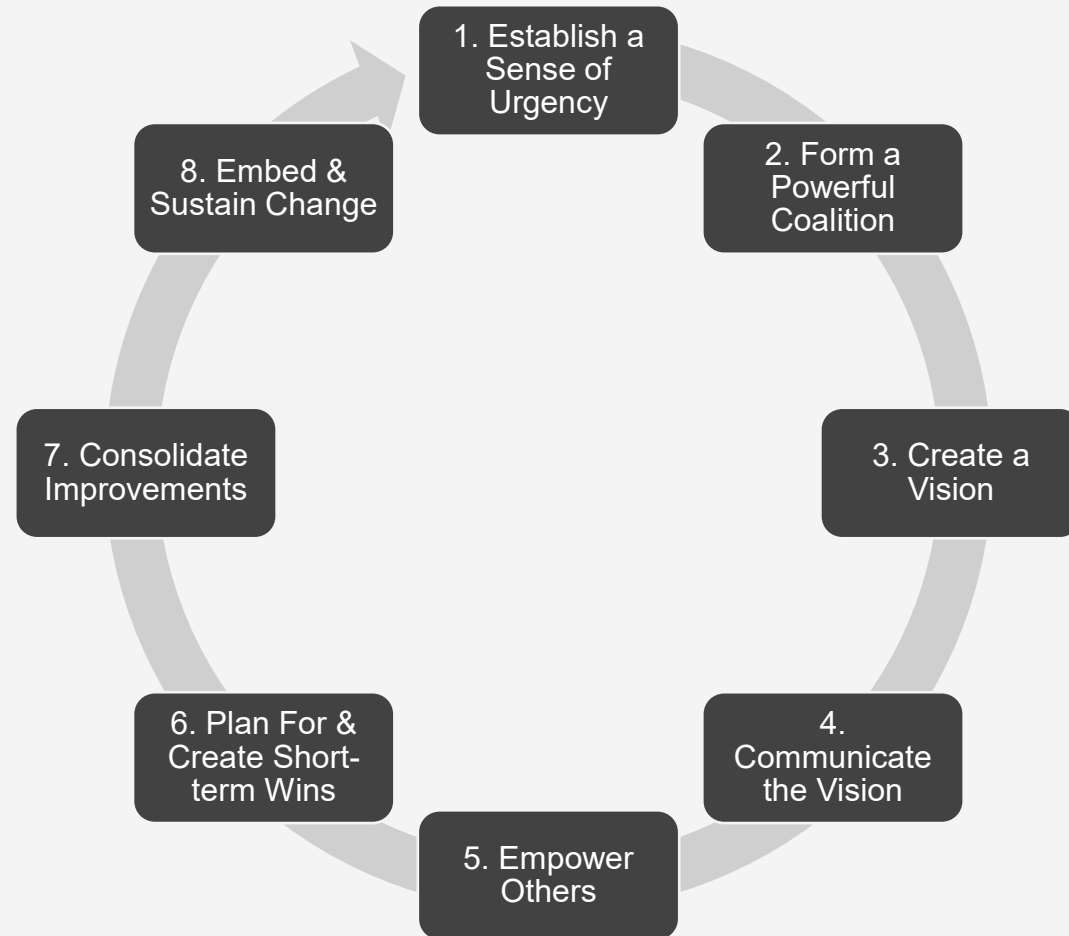

Design /w Azure Cloud Adoption Framework

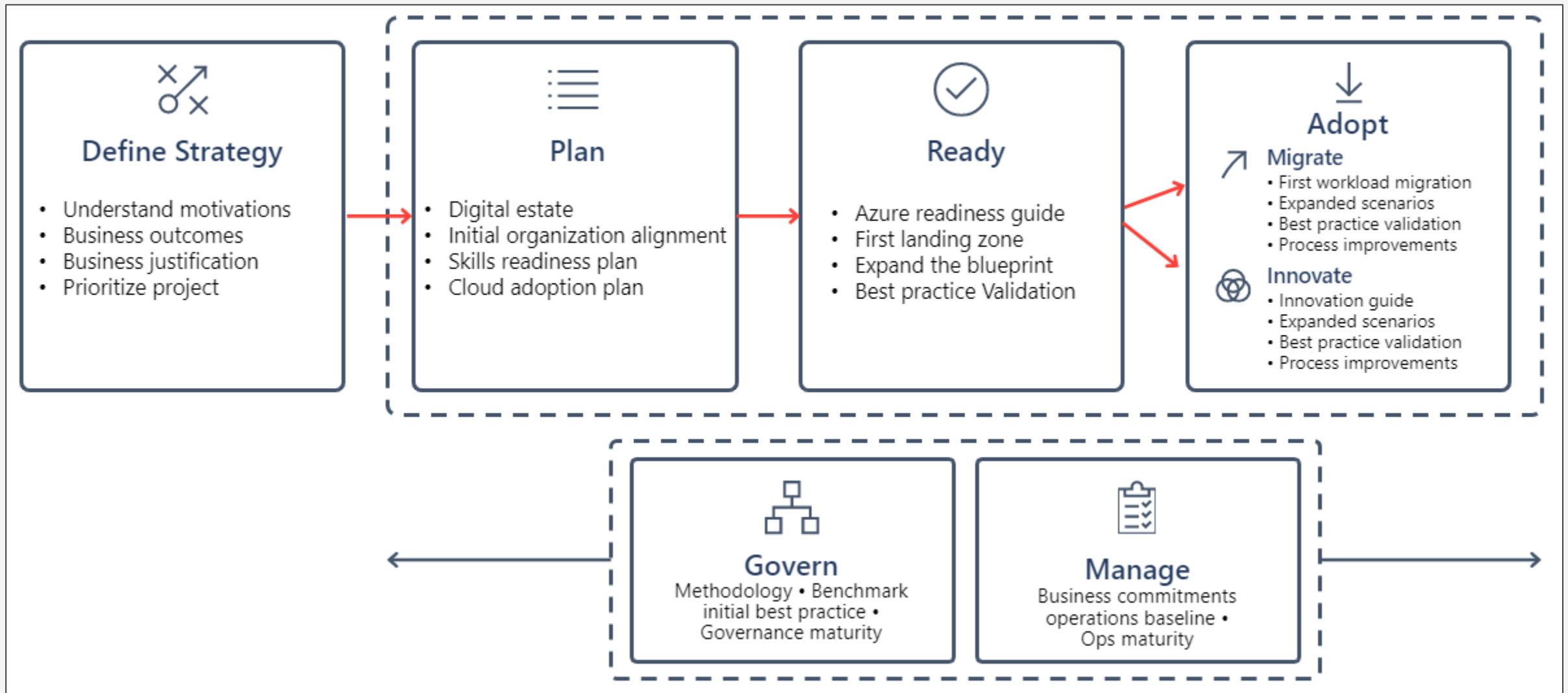

Verify /w Azure Well Architected Framework

Recommendations for your workload

[Export to CSV](#)

Actionable items to consider implementing to improve your workload across the five pillars of the Microsoft Azure Well-Architected Framework

Your overall results

EXCELLENT

You're all set. You meet the criteria necessary and are ready for successful cloud enablement.

Critical 0-33

Moderate 33-67

Excellent 67-100

Your result:
85/100

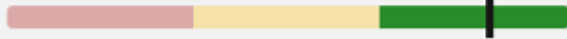

Categories that influenced your results

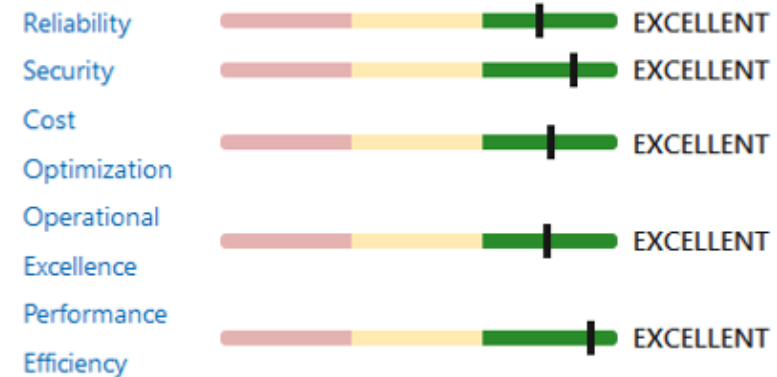

You can find out how to improve on individual categories by reviewing the [recommendations](#) below in the report.

Solution Delivery Approach

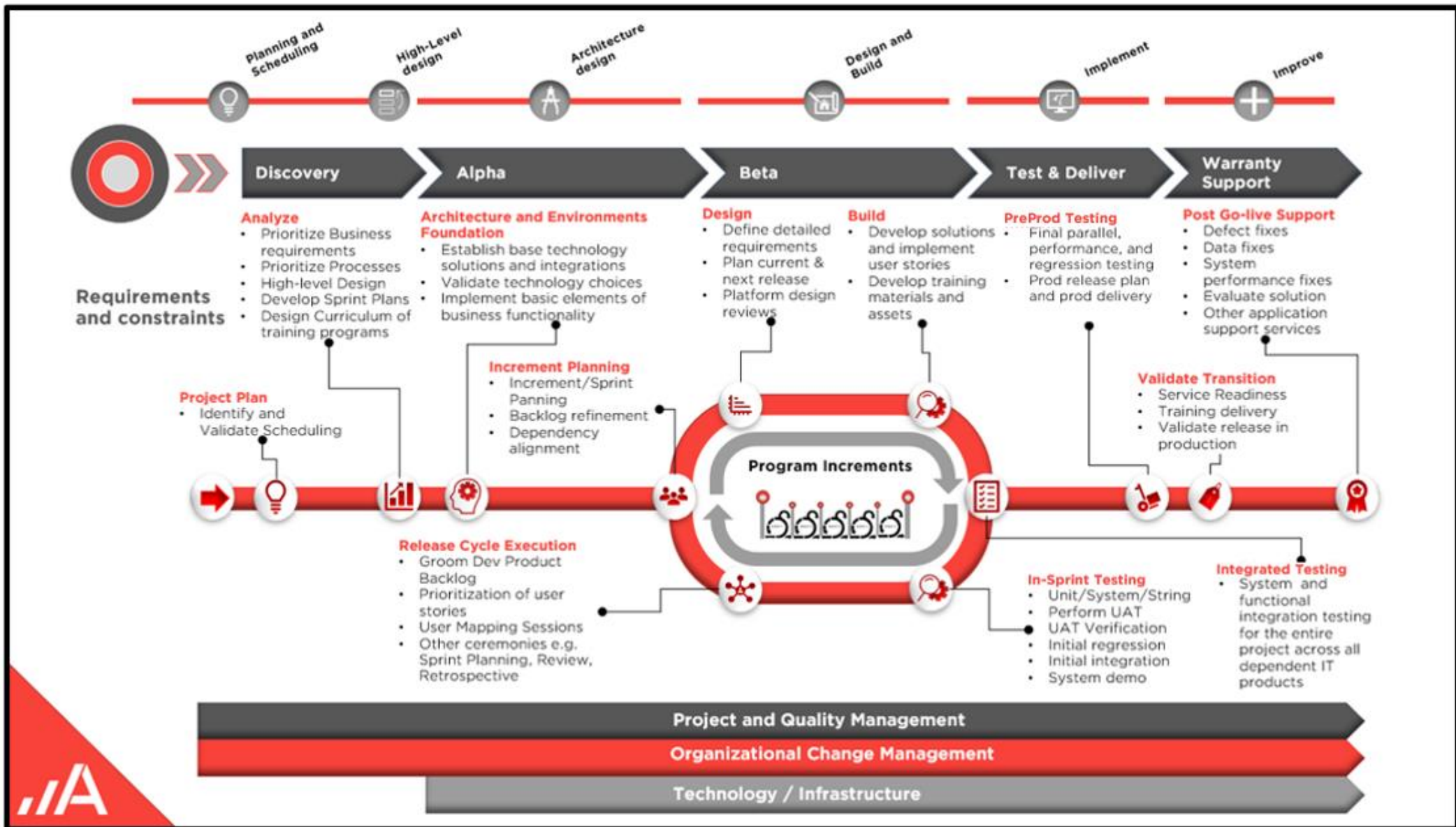

Application Migration Process

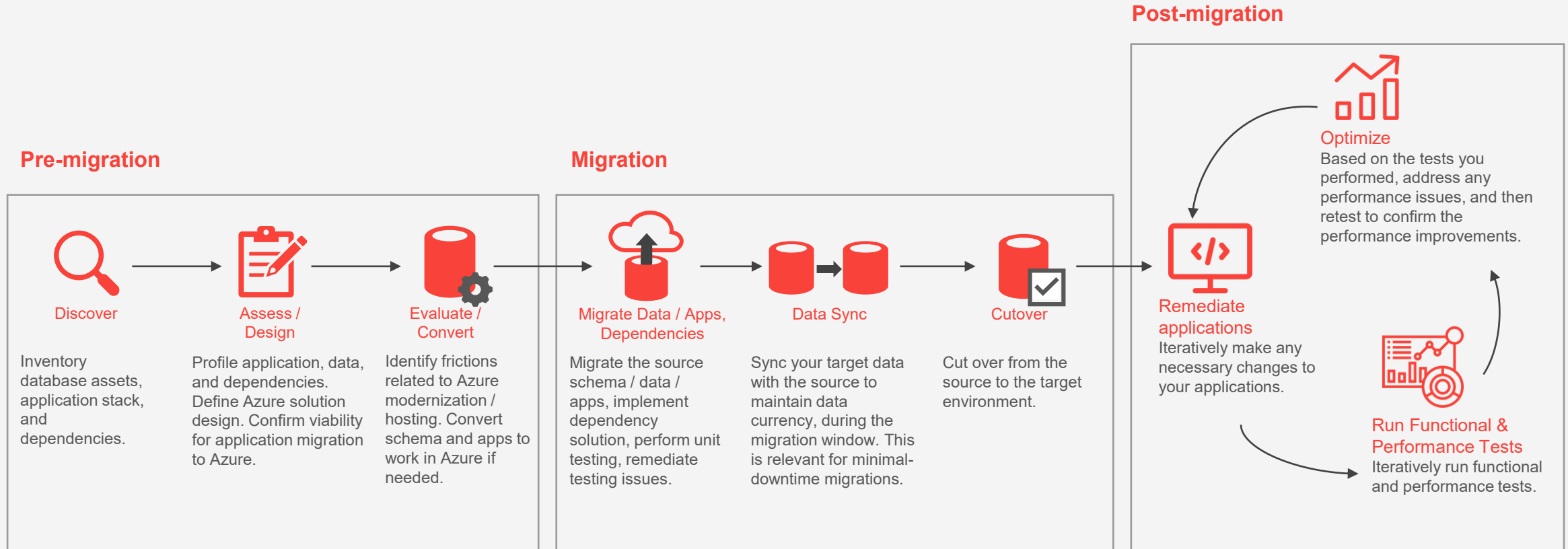

Perform in preprod, then repeat in prod.



Azure Application Decisioning

Web: Azure App Service
Data: Azure SQL Database
Identity: Azure AD
LB: Yes (Azure Application Gateway)
HA/DR: Yes (Azure Traffic Manager)
Auto Scale: Yes (Native)
CI/CD Integrated: Manual
Implementation: Simple
Recommendation: Use for .NET / PHP /
JAVA / PYTH Custom Web Applications
with no O/S dependencies

Managed PaaS

Web: Azure Kubernetes Service (IIS)
Data: Azure Kubernetes Service (SQL)
Identity: Azure AD
LB: Yes (AKS Controller)
HA/DR: Yes (Docker Repl and ATM)
Auto Scale: Yes (Native)
CI/CD Integrated: Implicit
Implementation: Complex
Recommendation: Use for any Custom
Web Applications and COTS Web
Applications approved for Docker /
Kubernetes

Container PaaS

Web: Azure Windows VM (IIS)
Data: Azure Windows VM (SQL)
Identity: AD Domain Service
LB: Yes (Azure Load Balancer)
HA/DR: Yes (ASR / ARV)
Auto Scale: Yes (Scale Sets)
CI/CD Integrated: Manual
Implementation: Complex
Recommendation: Use for COTS Web
Applications not approved for Docker /
Kubernetes

IaaS



Azure Network Security Layers

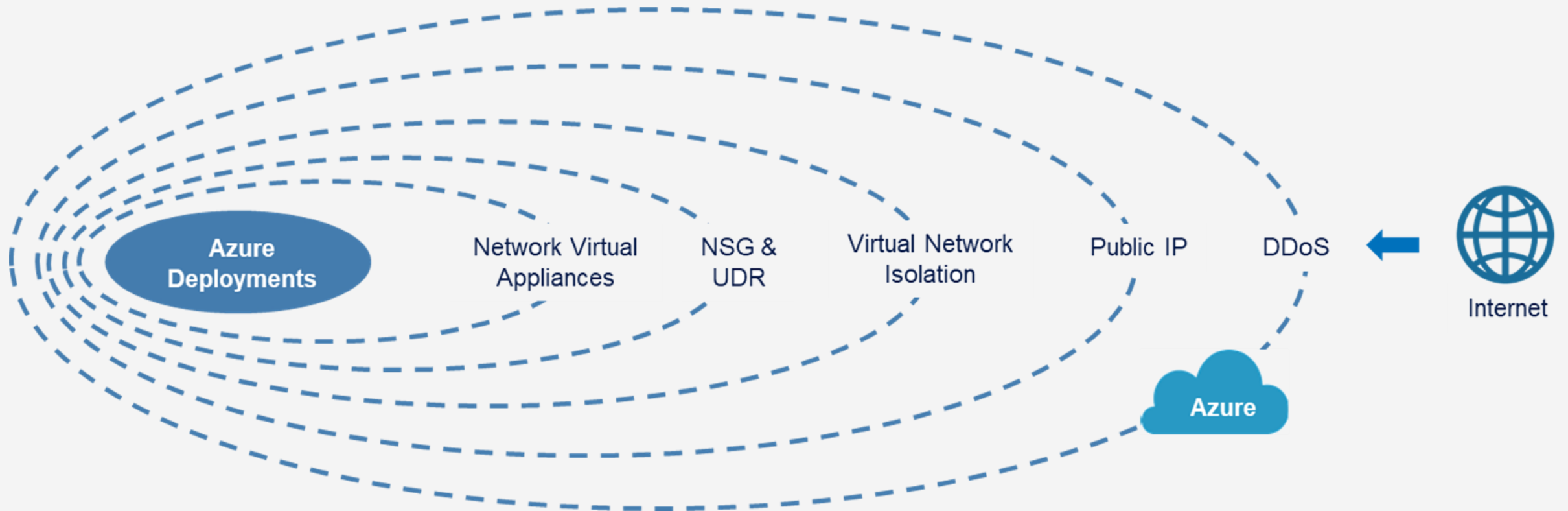

Azure Data Security Layers

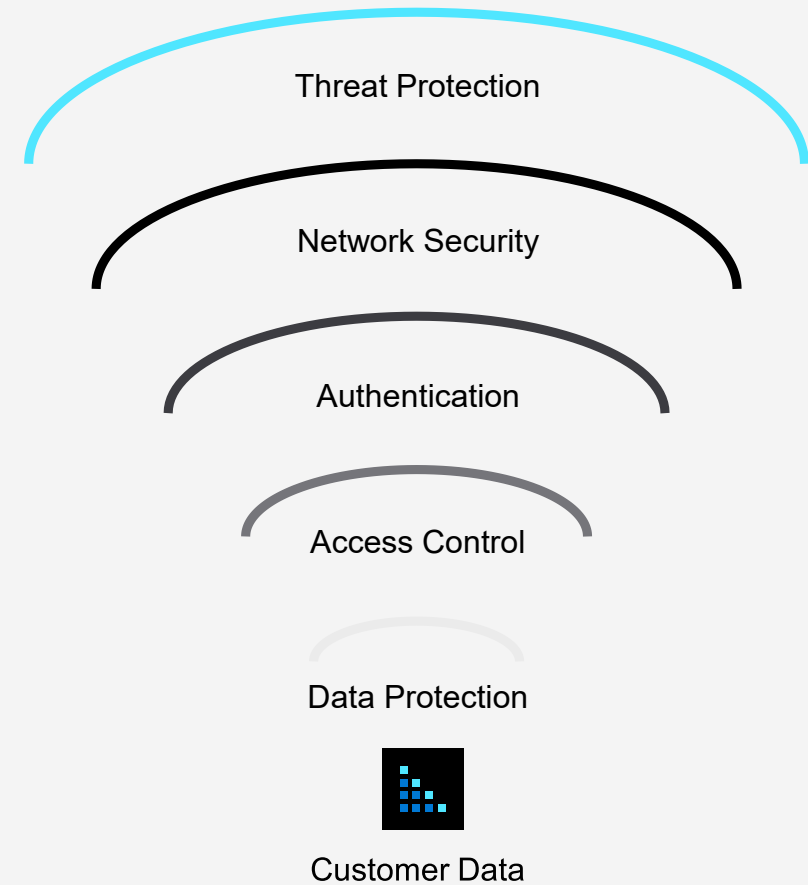

Multiple levels of security between the user and data.



Azure Service Security

Role	Service	Details
Secret Key	Azure Key Vault	Store all secrets (credentials, certificates, ...) in a secure vault, and call from vault in processes.
Monitoring / Reporting	Azure Monitor Azure Log Analytics	Log Analytics covers event and performance monitoring and response.
SIEM / SOAR	Azure Sentinel	ML driven security incident / response detection and resolution.
Policy	Azure Policy	Applies Azure service policies across a subscription / management group.
Exposure Detection	Azure Security Centre	Azure Security Centre provides the Azure centric view.
Endpoint Management	Azure Application Gateway Azure API Management Azure Private Link	←Route external connections to internal resources. ←Secure endpoint routing for external / internal connections. ←Provision private endpoints for Azure PaaS services.
Traffic Management	Azure Front Door Azure Traffic Manager	←HTTP connection routing to regional / failover resources. ←DNS connection routing routing to regional / failover resources.



Azure Data Security

Resources	Encryption at Rest	Encryption in Transit	Field Level Encryption	Access Control
Azure SQL Database	✓	✓	Masking / Encryption Supported	Database, Object, Row, Column
Azure Data Lake Storage	✓	✓	Not Applicable	Folder, File
Power BI	✓	✓	Not Supported	Dataset, Table, Column, Row
Azure Data Pipelines	✓	✓	Masking / Encryption Supported	Dataset, Table, Column, Row
Azure Synapse SQL Runtime	✓	✓	Masking Supported, Encryption Supported Soon	Database, Object, Row, Column
Azure Synapse Spark Runtime	✓	✓	Masking / Encryption Supported	Database, Object, Row, Column



Azure DevOps CI / CD

- Developers check-in code in DevOps development branch
- Code review by Lead/Peers
- Pull request to move code to Master branch
- Automatically triggers build & test processes once pull request is complete
- Automatically triggers release pipeline to deploy code in multiple target environments through gating approvals
- Azure DevOps maintains logs of all build, tests, release/deploy tasks
- Pipelines are executed through Releases in DevOps

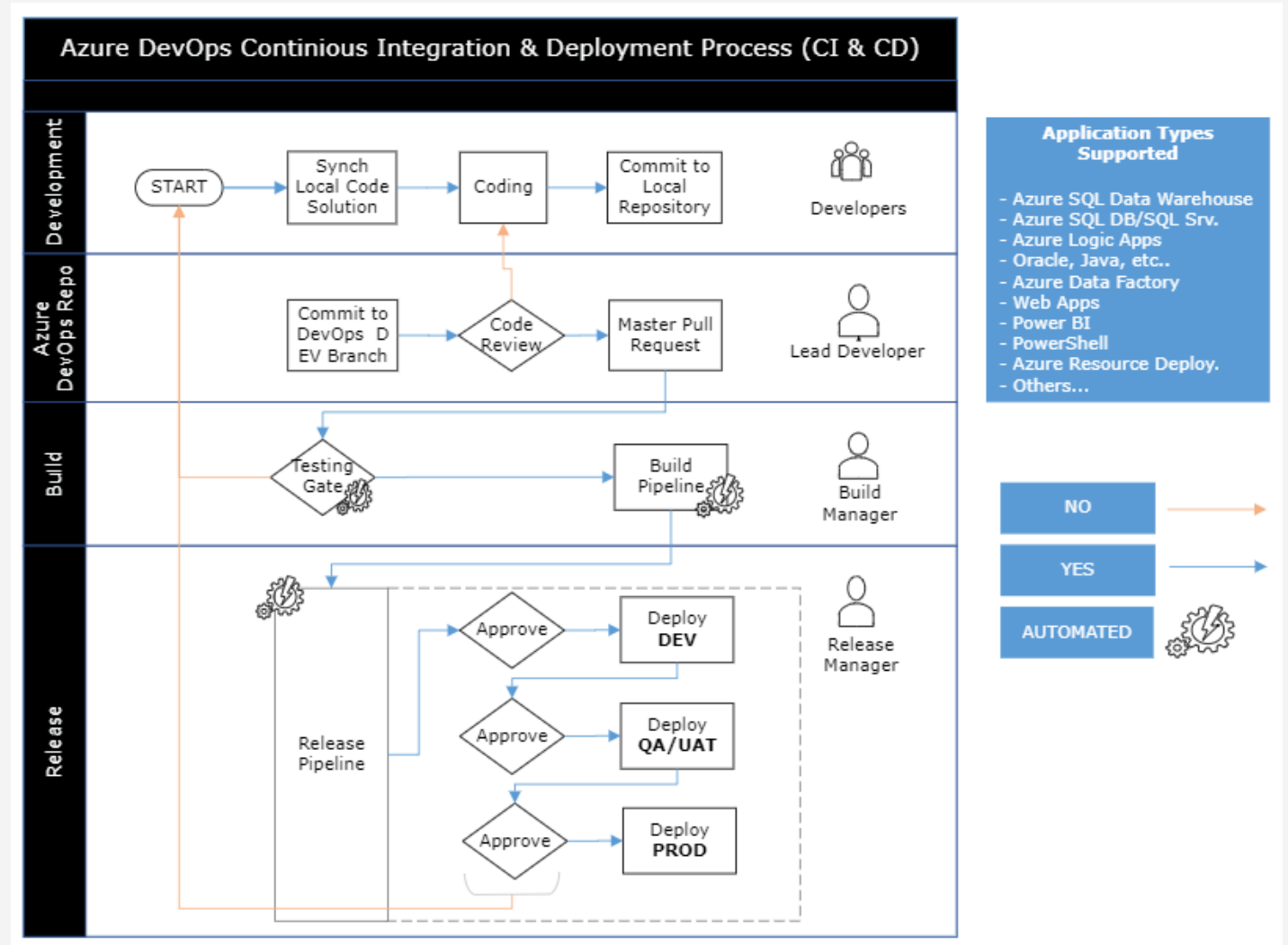

GDPR Compliance

Azure provides a robust set of security and data management capability that enables GDPR compliance.

As standard practice, Adatastra implements these security and data management services for our customers, to position our Azure solutions for compliance, and to enable successful compliance auditing

Capabilities Adatastra will enable to ensure future GDPR compliance:

- Enable Azure Data Subject Request capability to align to GDPR “right to be forgotten” requirements
 - [Azure Data Subject Requests for the GDPR and CCPA - Microsoft GDPR | Microsoft Docs](#)
- Implement Azure Security Center to activate unified security management and advanced threat protection
 - [Azure Security Center | Microsoft Azure](#)
- Configure Azure Policy to ensure types of data stay within their required regions
 - [Azure Policy Cloud and Compliance Management | Microsoft Azure](#)
- Follow Azure GDPR Blueprint best practices to ensure architecture and configuration is compliant
 - [AzureGDPR/Azure Security and Compliance Blueprint - GDPR IaaS WebApp Overview.md at master · sukykaur/AzureGDPR · GitHub](#)
- Leverage MS Cloud Compliance Center to evaluate current risk and prepare for GDPR audits
 - [Home - Microsoft 365 compliance](#)
- Adopt Azure Information Protection to scan, label, and protect sensitive data
 - [Azure Information Protection | Microsoft Azure](#)



./ADASTRA

Adastra Landing Zone Approach



Azure Well-Architected Framework & CAF

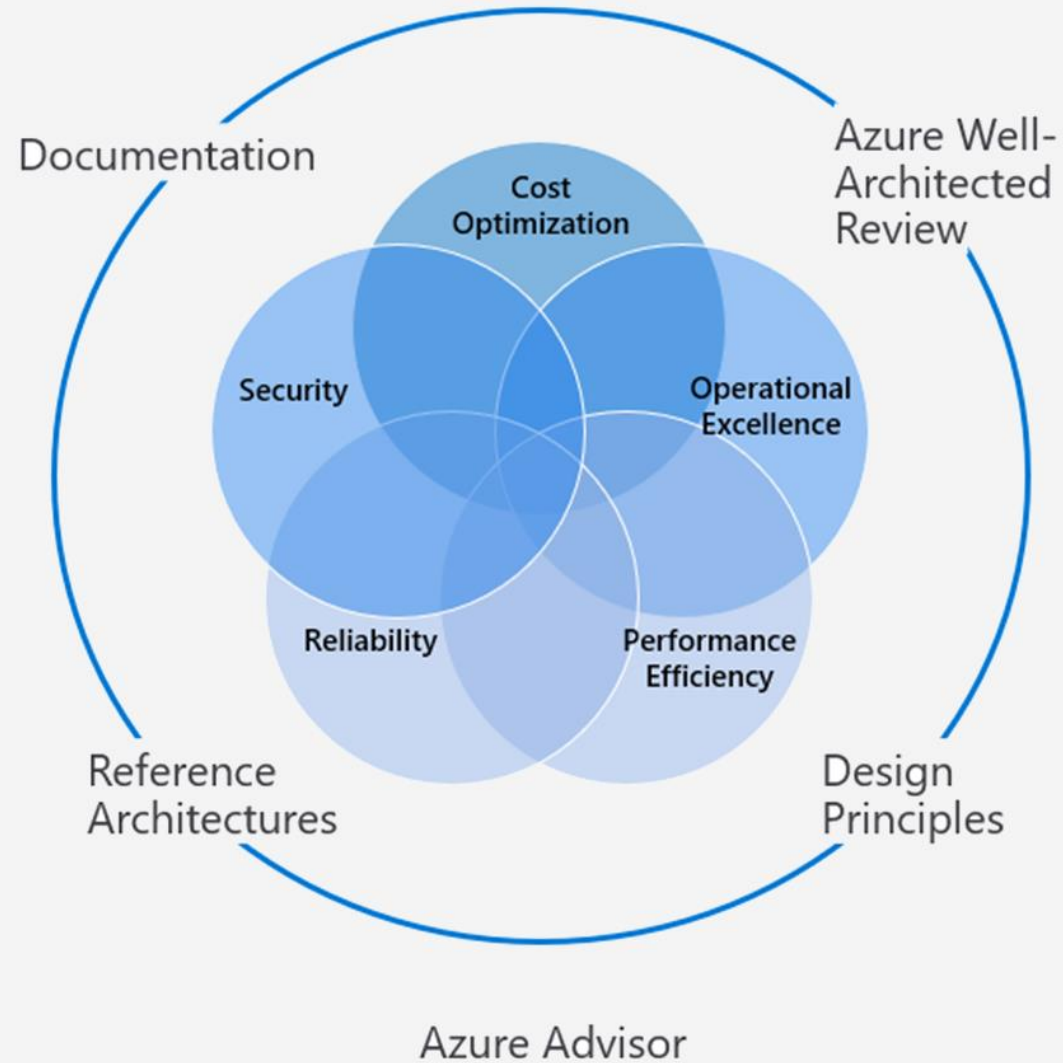

Microsoft Cloud Adoption Framework for Azure

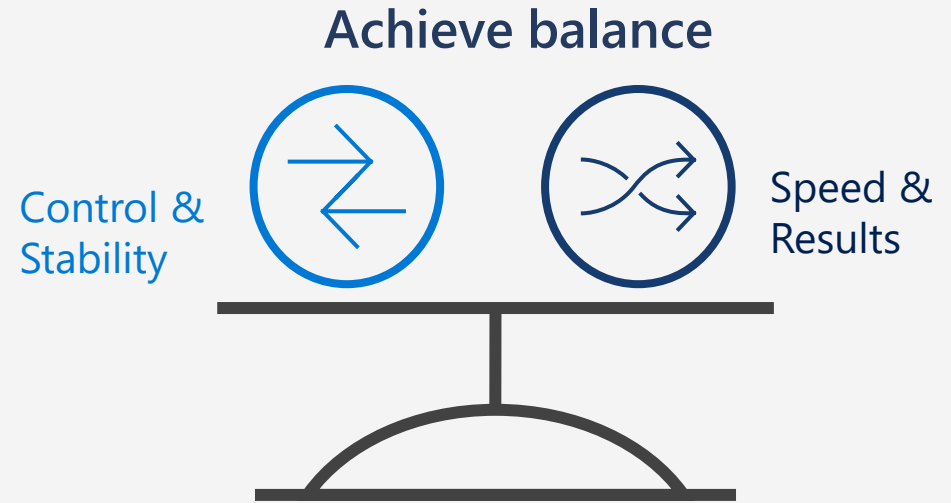
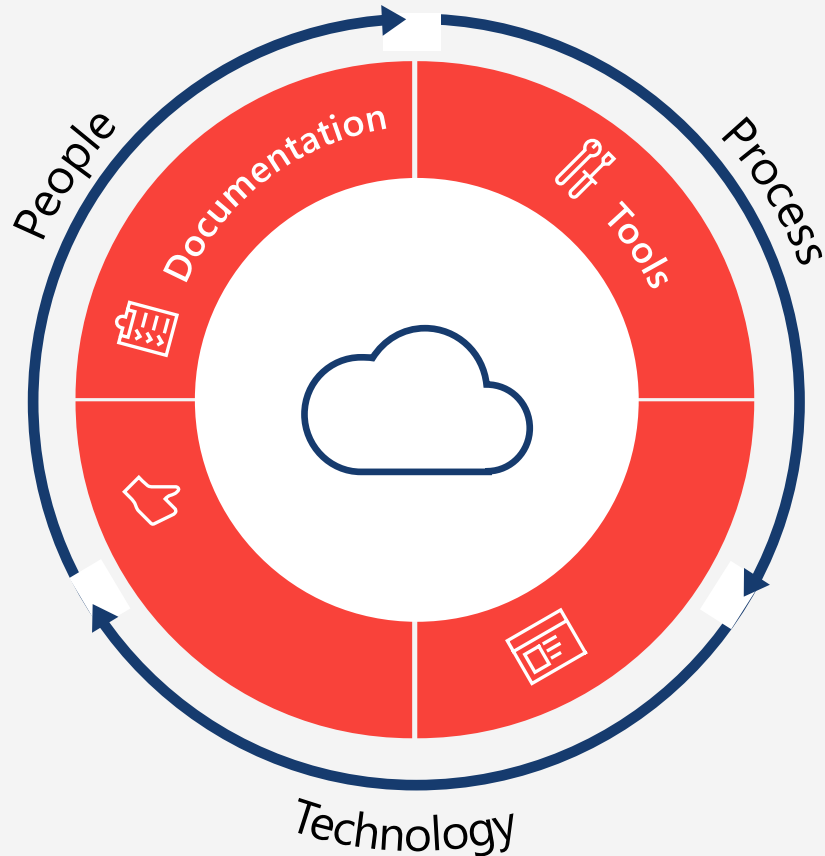

Align **business, people and technology strategy** to achieve business goals with **actionable, efficient, and comprehensive** guidance to deliver fast results with control and stability.

Cloud Adoption Framework

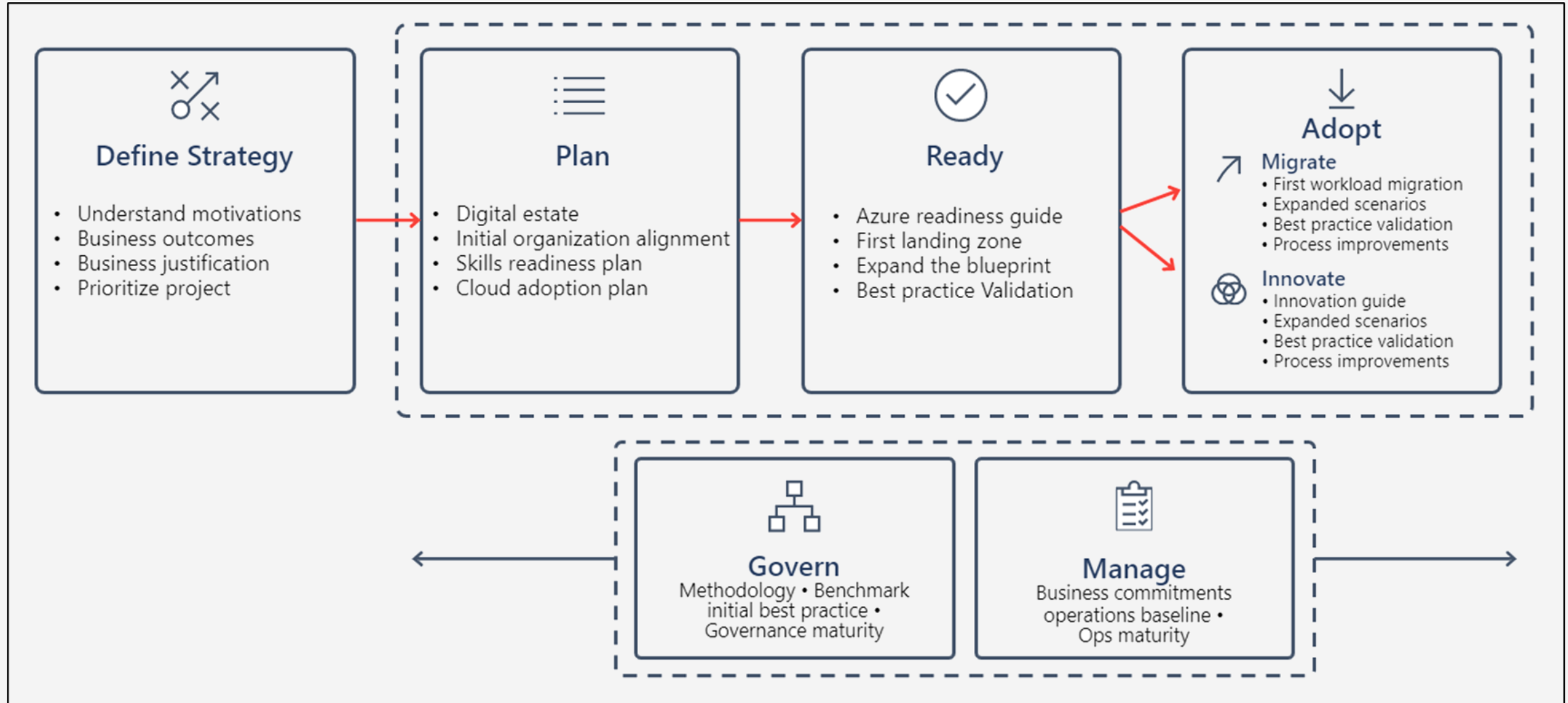

Cloud Governance

This demonstrates the interactions between business risk, policy and compliance, monitor and enforce to create a governance strategy.

Business Risks

Document evolving business risks and the business tolerance for risk, based on data classification and application criticality

Policy & Compliance

Convert Risk decisions into policy statements to establish cloud adoption boundaries

Process

Establish processes to monitor violations and adherence to corporate policies



Disciplines of Cloud Governance

Cost Management

Evaluate & Monitor costs, limit IT Spend, scale to meet need, create cost accountability

Security Baseline

Ensure compliance with IT security requirements by applying a security baseline to all adoption efforts

Resource Consistency

Ensure consistency in resource configuration, Enforce practices for on-boarding, recovery, and discoverability

Identity Baseline

Ensure the baseline for identity and access are enforced by consistently applying role definitions and assignments

Deployment Acceleration

Accelerate deployment through centralization, consistency, and standardization across deployment templates

Foundation Step: Azure Landing Zone

1. Creation of Naming standards
2. Creation of subscriptions
3. Setup of Azure DevOps project
4. Build out of Azure foundation
 1. Management Group
 2. Accounts
 3. Vnets
 4. Subnets
 5. VNet Peering

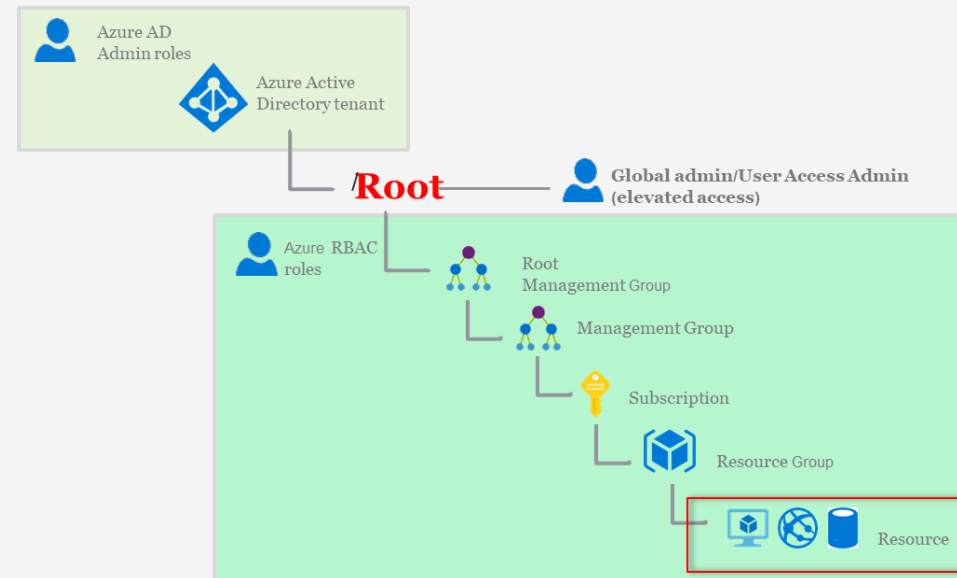
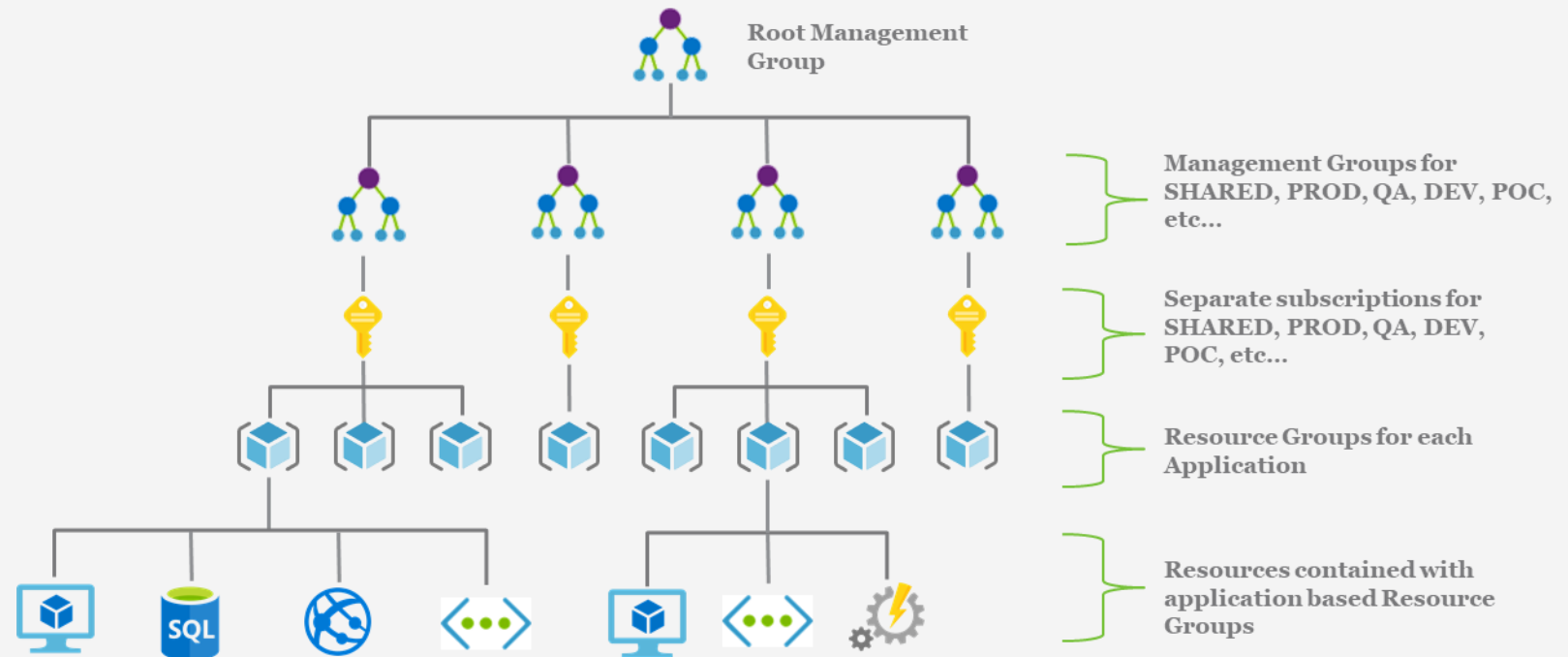

Foundation Step: Azure Governance Design

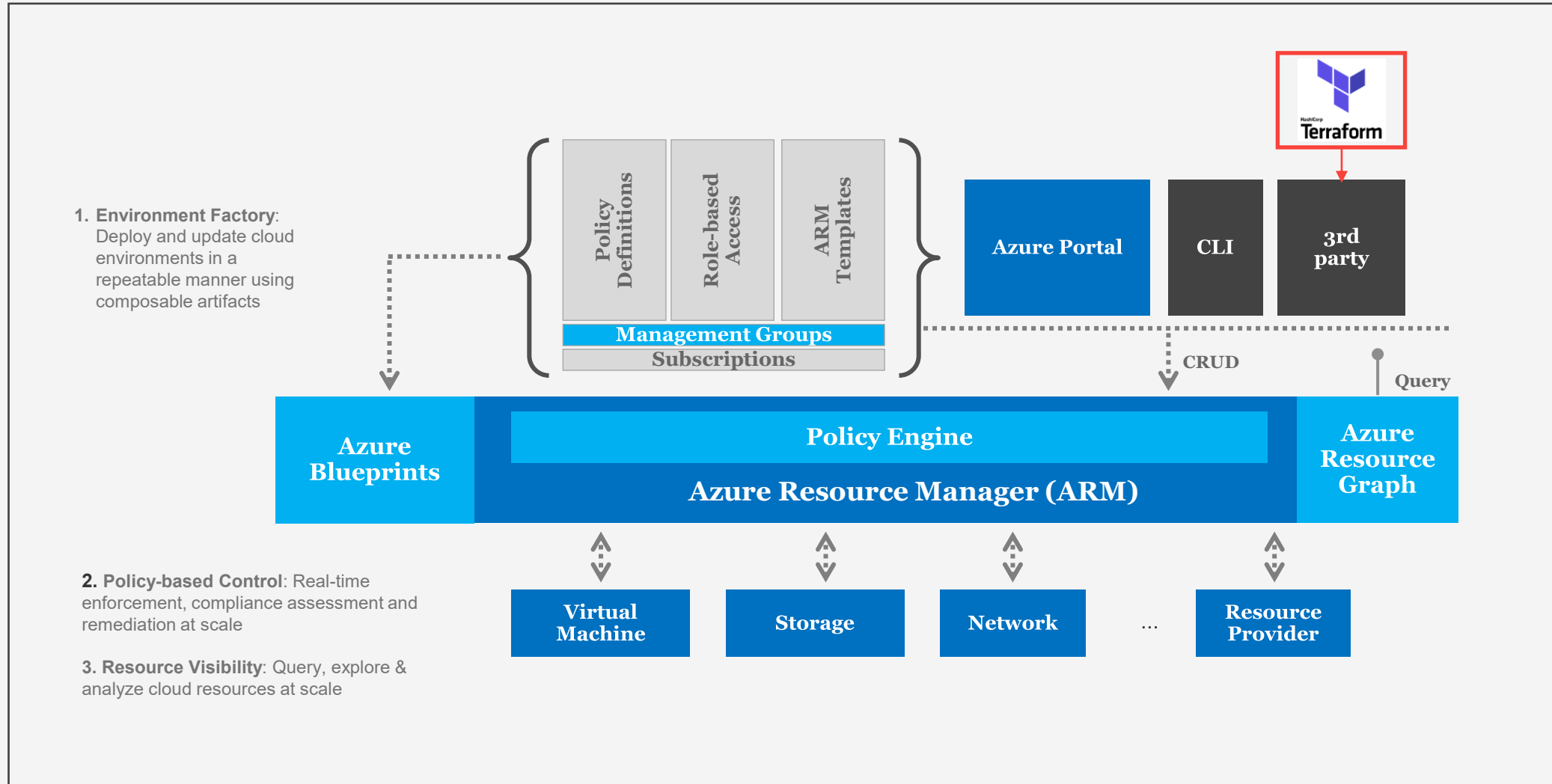

Foundation Step: Azure VNET Integration

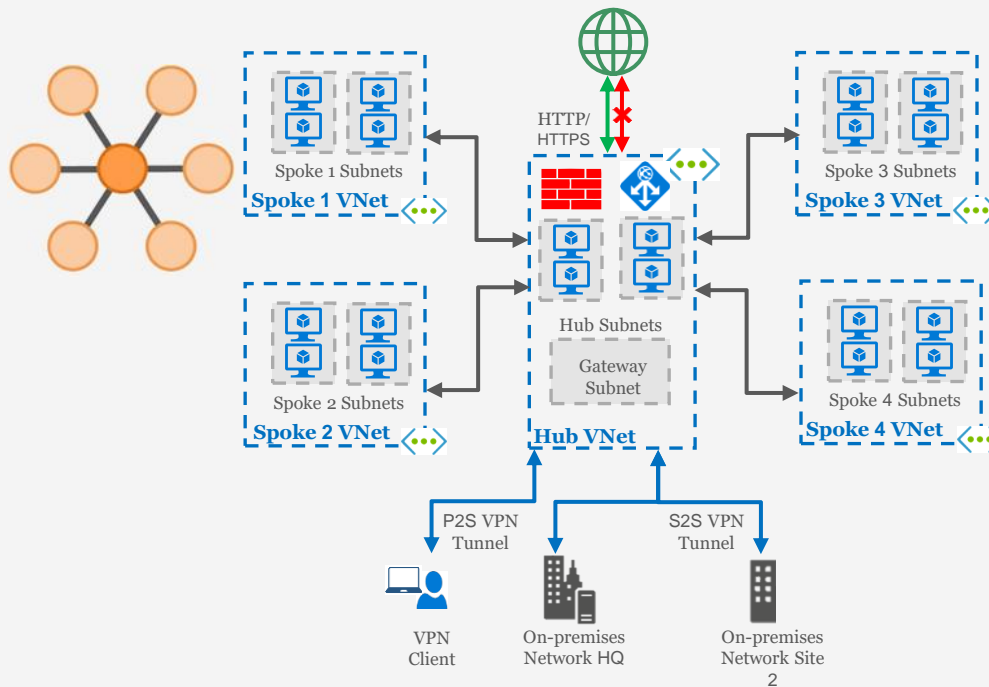

Virtual network peering enables the seamless connecting of Azure virtual networks. Once peered, the virtual networks appear as one, for connectivity purposes. The traffic between virtual machines in the peered virtual networks is routed through the Microsoft backbone infrastructure, much like traffic is routed between virtual machines in the same virtual network, through private IP addresses only

Azure Supports:

- **VNet peering** - connecting VNets within the same Azure region
- **Global VNet peering** - connecting VNets across Azure regions

Azure Network Security Layers

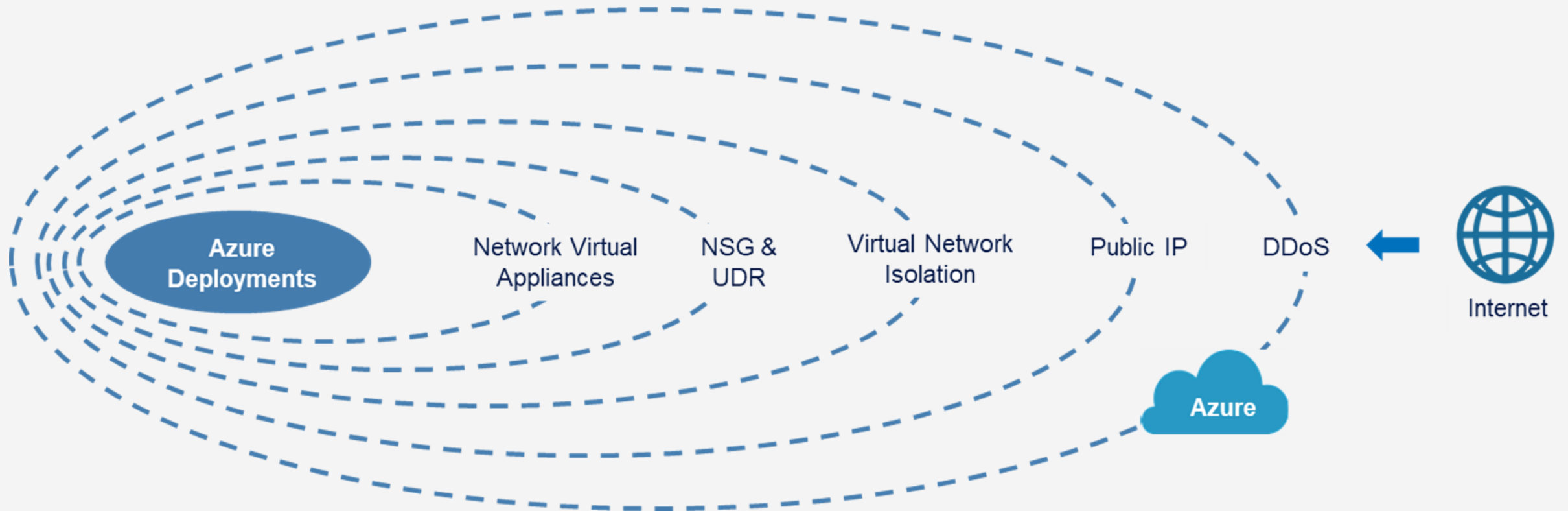

Application Gateway + WAF

1. WAF on Application Gateway is based on Core Rule Set (CRS) 3.1, 3.0, or 2.2.9 from the Open Web Application Security Project (OWASP).
2. Secure Sockets Layer (SSL/TLS) termination
3. Autoscaling
4. Zone redundancy
5. Static VIP
6. Ingress Controller for AKS
7. URL-based routing
8. Multiple-site hosting
9. Redirection
10. Session affinity
11. Websocket and HTTP/2 traffic
12. Connection draining
13. Custom error pages
14. Rewrite HTTP headers and URL
15. Sizing

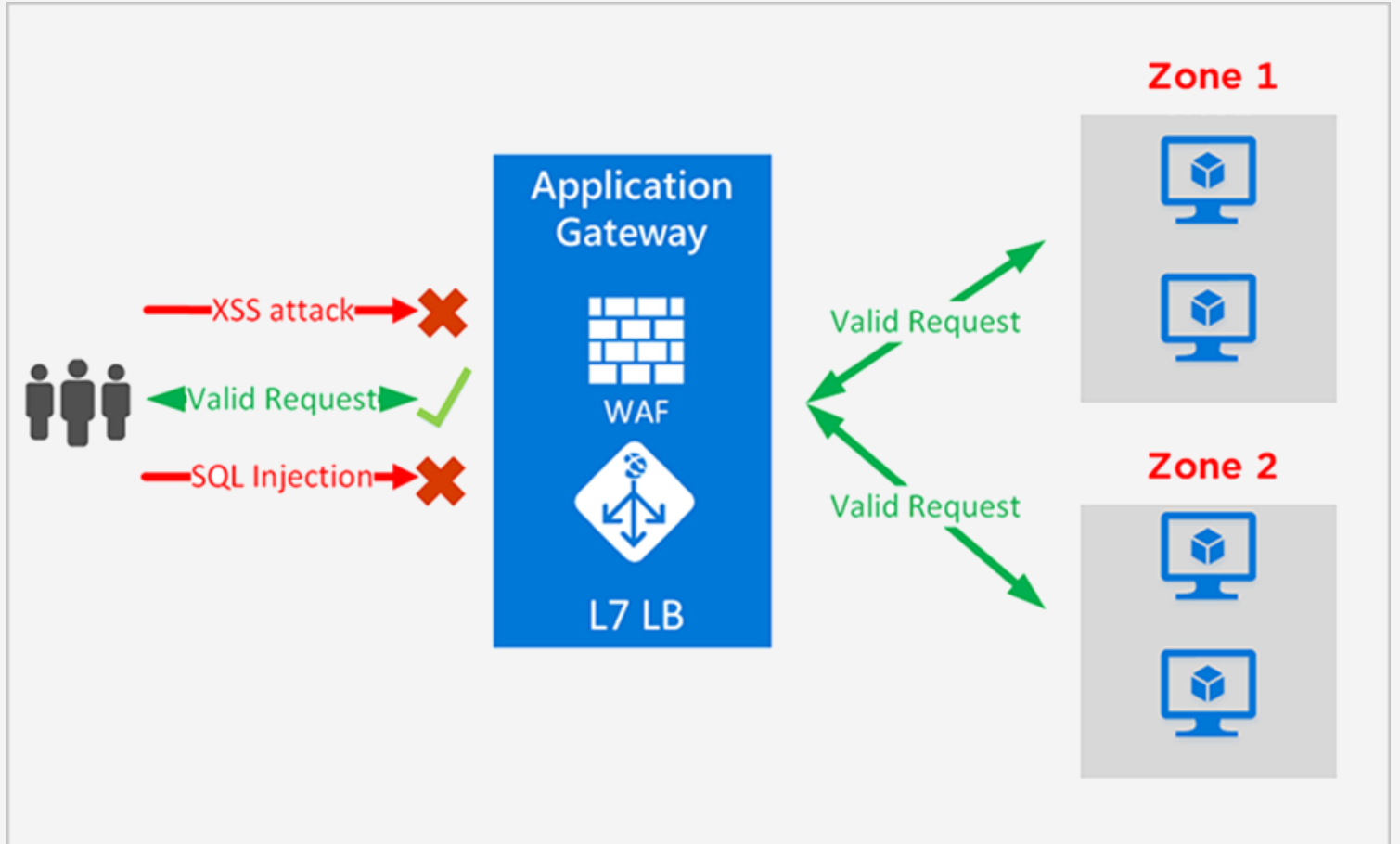

How an Application Gateway Works

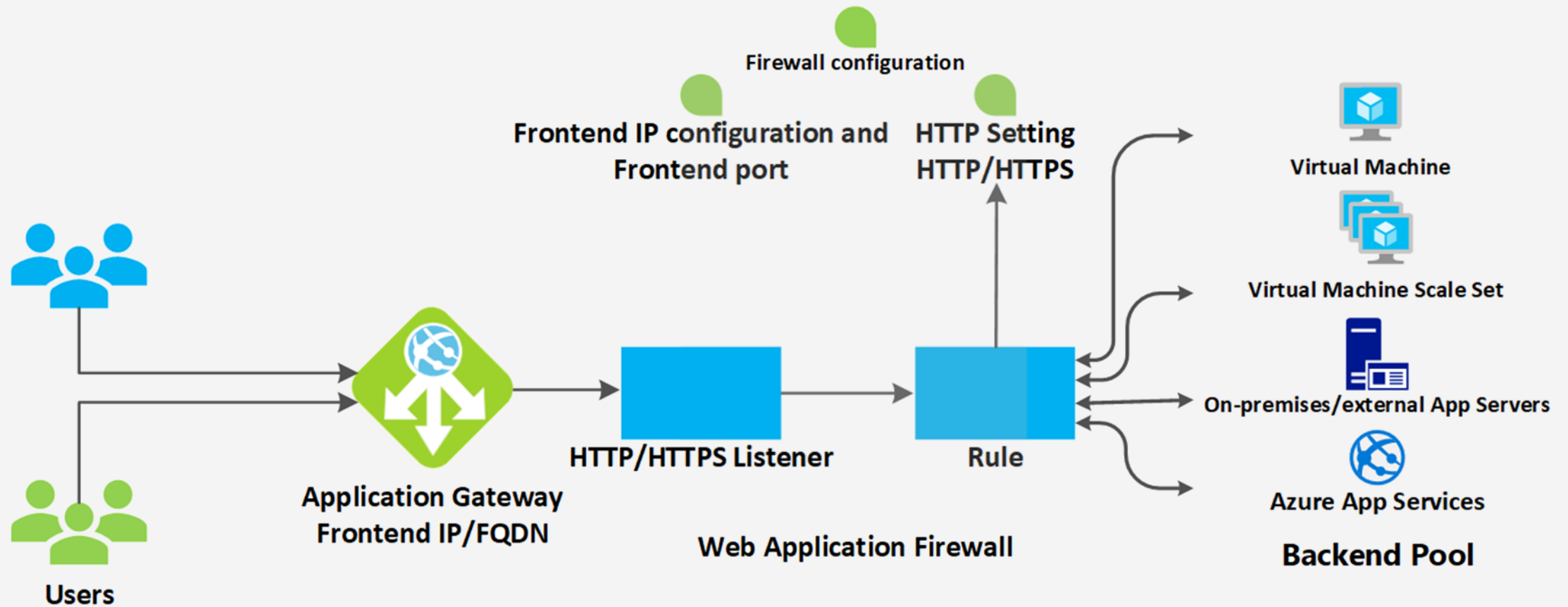

Azure Firewall

Azure Firewall Standard provides L3-L7 filtering and threat intelligence feeds directly from Microsoft Cyber Security. Threat intelligence-based filtering can alert and deny traffic from/to known malicious IP addresses and domains which are updated in real time to protect against new and emerging attacks.

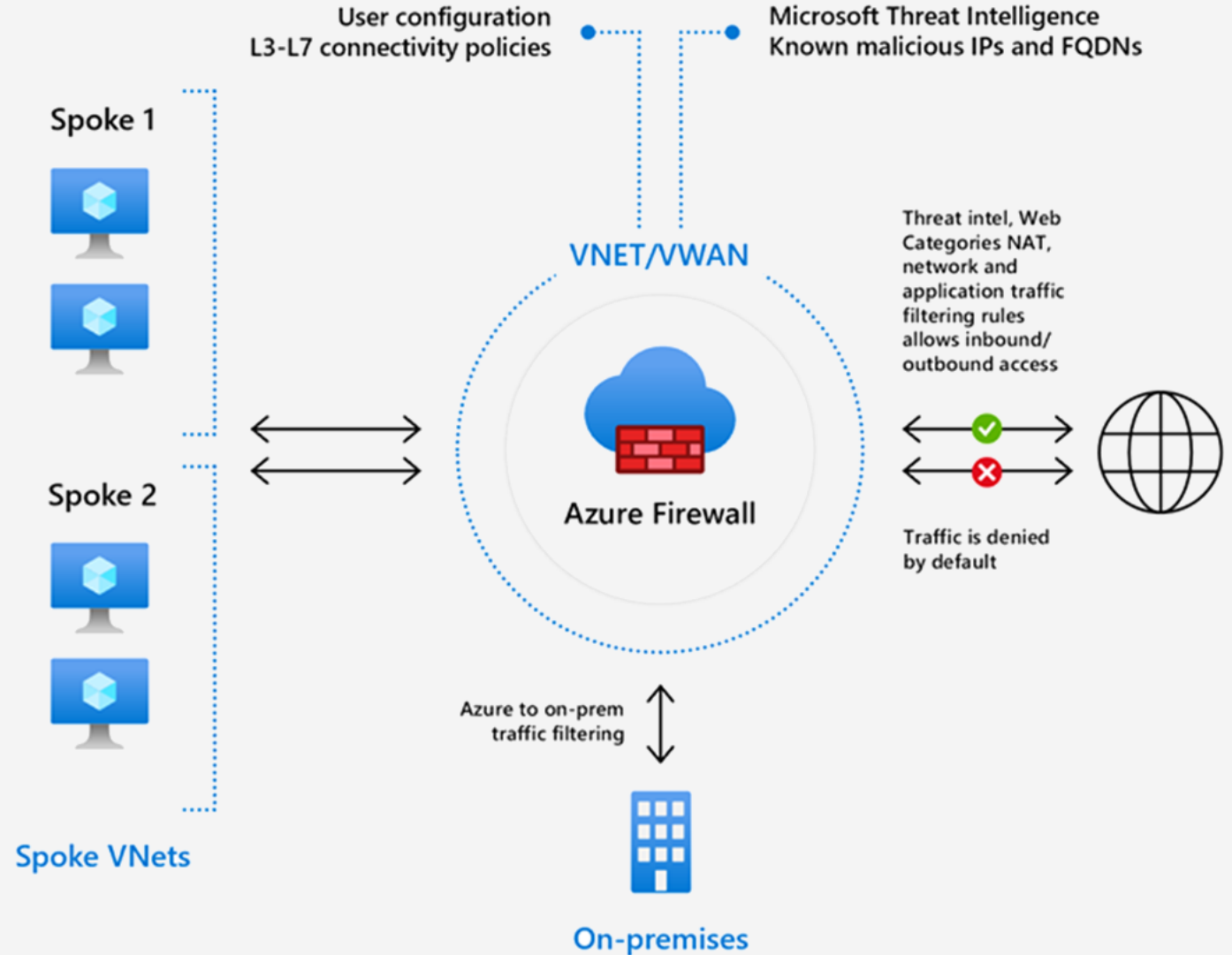

Azure High Availability

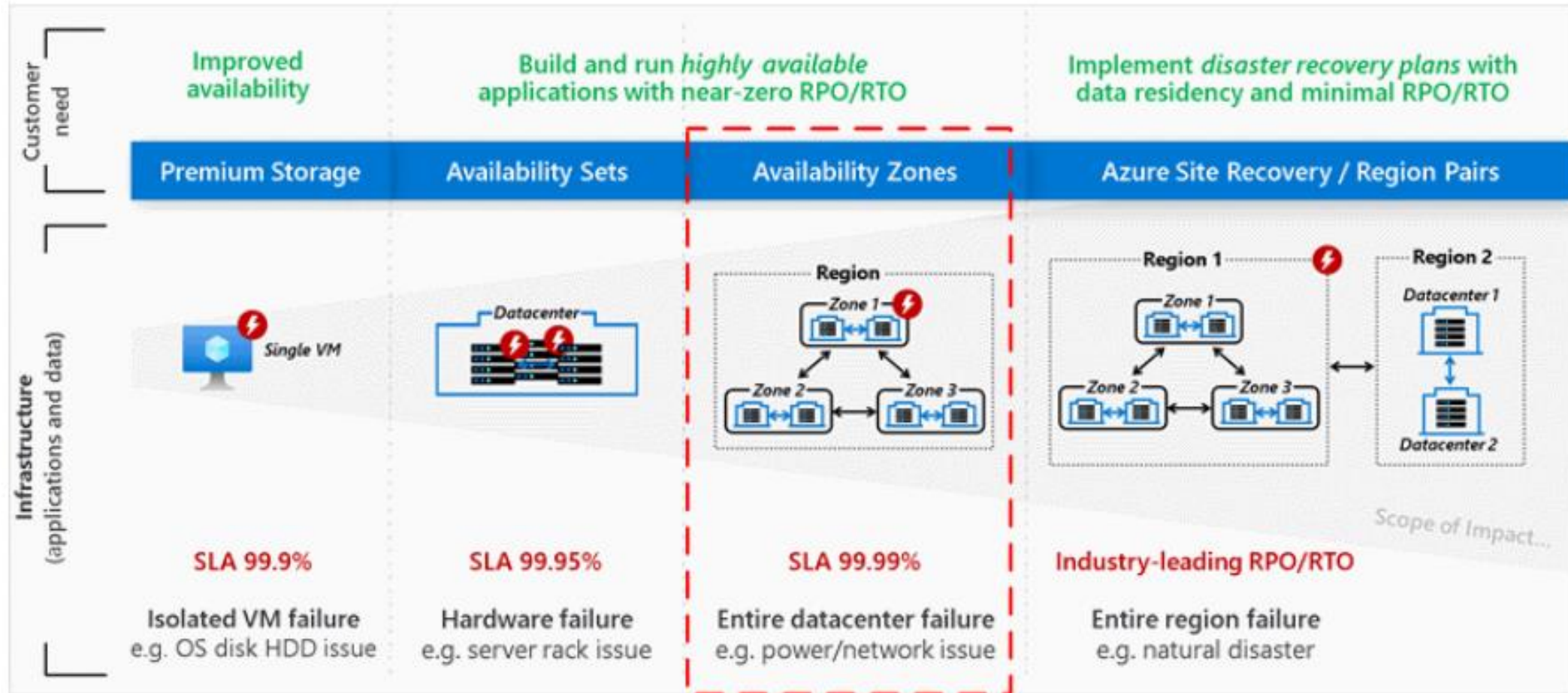

<https://docs.microsoft.com/en-us/azure/architecture/high-availability/building-solutions-for-high-availability>



Infrastructure as Code (IaC)

Infrastructure as Code (IaC) is the process of managing and provisioning computing infrastructure (processes, bare-metal servers, virtual servers, etc.) and their configuration through machine-processable definition files, rather than physical hardware configuration or the use of interactive configuration tools.

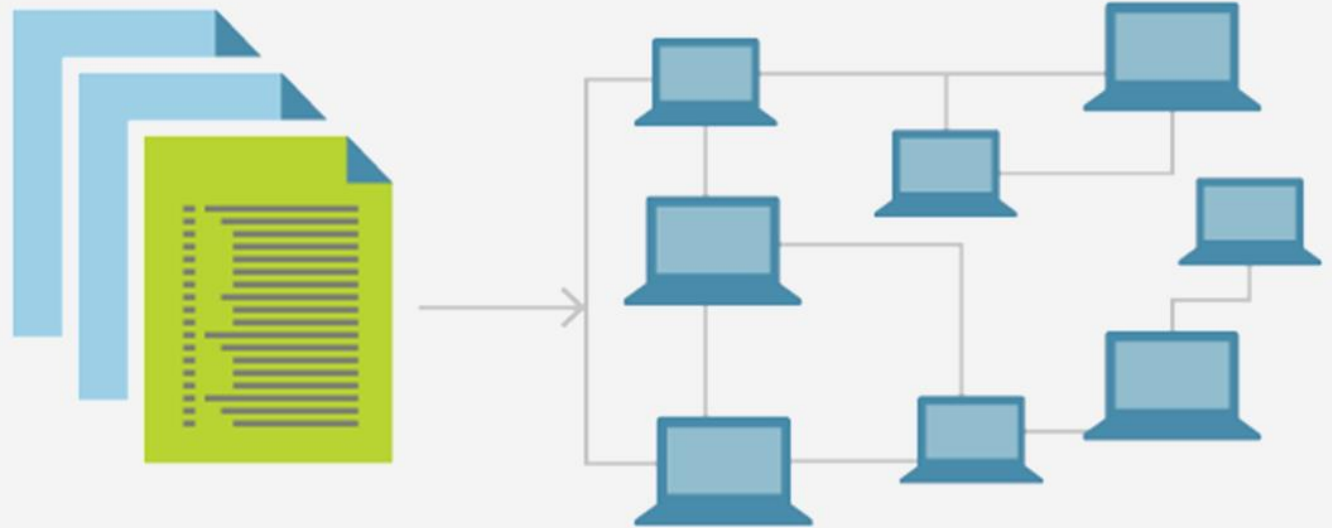

Azure DevOps



Azure Boards

Deliver value to your users faster using proven agile tools to plan, track, and discuss work across your teams.



Azure Pipelines

Build, test, and deploy with CI/CD that works with any language, platform, and cloud. Connect to any Git provider and deploy continuously.



Azure Repos

Get unlimited, cloud-hosted private Git repos and collaborate to build better code with pull requests and advanced file management.



Azure Test Plans

Test and ship with confidence using manual and exploratory testing tools.



Azure Artifacts

Create, host, and share packages with your team, and add artifacts to your CI/CD pipelines with a single click.

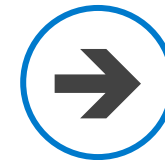

<https://azure.com/devops>

Cloud Operation Model

A comprehensive set of capabilities needed to successfully operate cloud-based environments

DevOps and Infrastructure Automation

- Release Management
- Continuous Integration
- Continuous Deployment
- App Version Support

ITIL Service Management/ServiceNow*

- Triage & Escalation
- Automated Monitoring, Ticketing & Alerting
- Change & Configuration Management
- Incident and Problem Management
- Event Management

Cost Management & Billing

- Account Management
- Consolidated billing
- Cost allocation & optimization

Monitoring and Logging

- Centralized log aggregation across platforms
- Infrastructure capacity performance and Network health Monitoring
- Security event and incident monitoring through SIEM solution

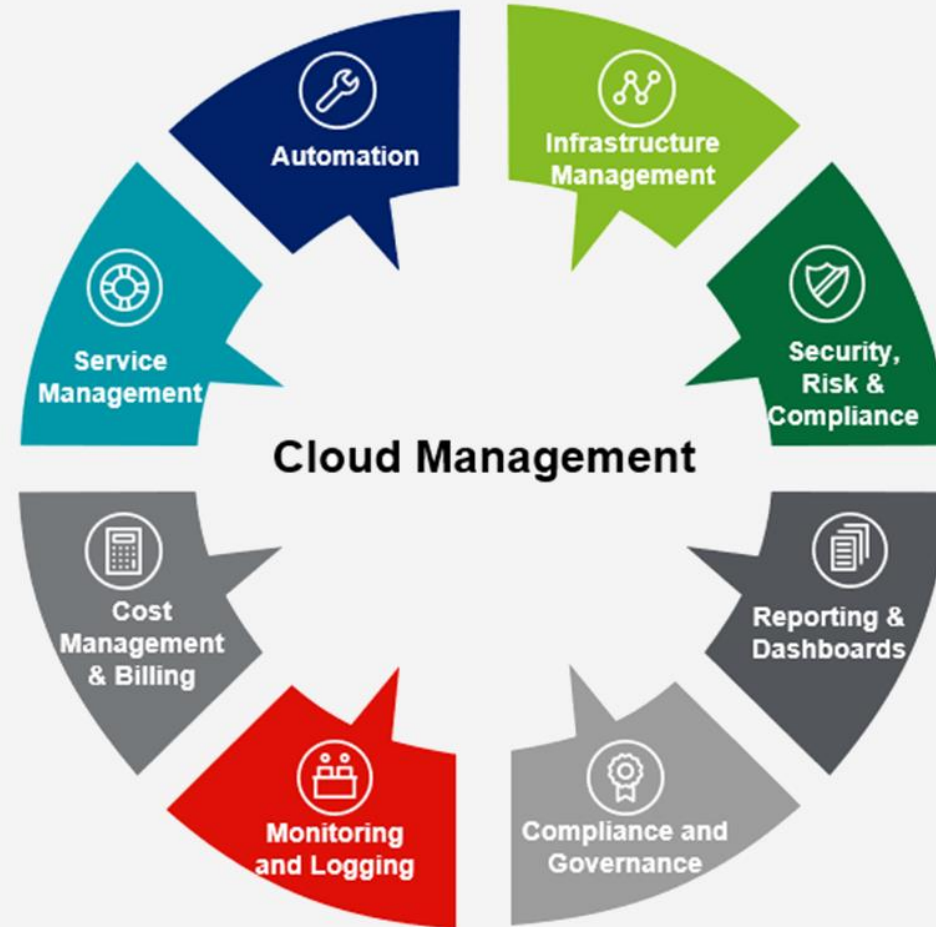

Infrastructure Management

- Infrastructure Provisioning
- Site-to-Site VPN Connection management; IP and routing configuration
- OS Image/Patch Management
- Backup Management & Disaster Recovery
- Client Compartmentalization

Security, Risk & Compliance

- Identity & Access Management
- Vulnerability Management
- Data Protection, Encryption & Privacy
- Security Monitoring
- Infra. Security Hardening
- Antivirus management

Reporting & Dashboards

- Service Management Reports
- Consumption & Billing Reports
- Account Health Check Reports
- Security & Compliance Reports

Compliance and Governance

- Integrated Controls Framework
- SOC2, PIPEDA, ISO 27001, PCI Compliance certification roadmap
- Policy based resources provisioning
- Tagging and Quota management

Cloud Operating Model Journey

The journey to achieve target state maturity will require tangible changes to organization culture and skillsets, ways of working, and also service delivery and operations to achieve long term success

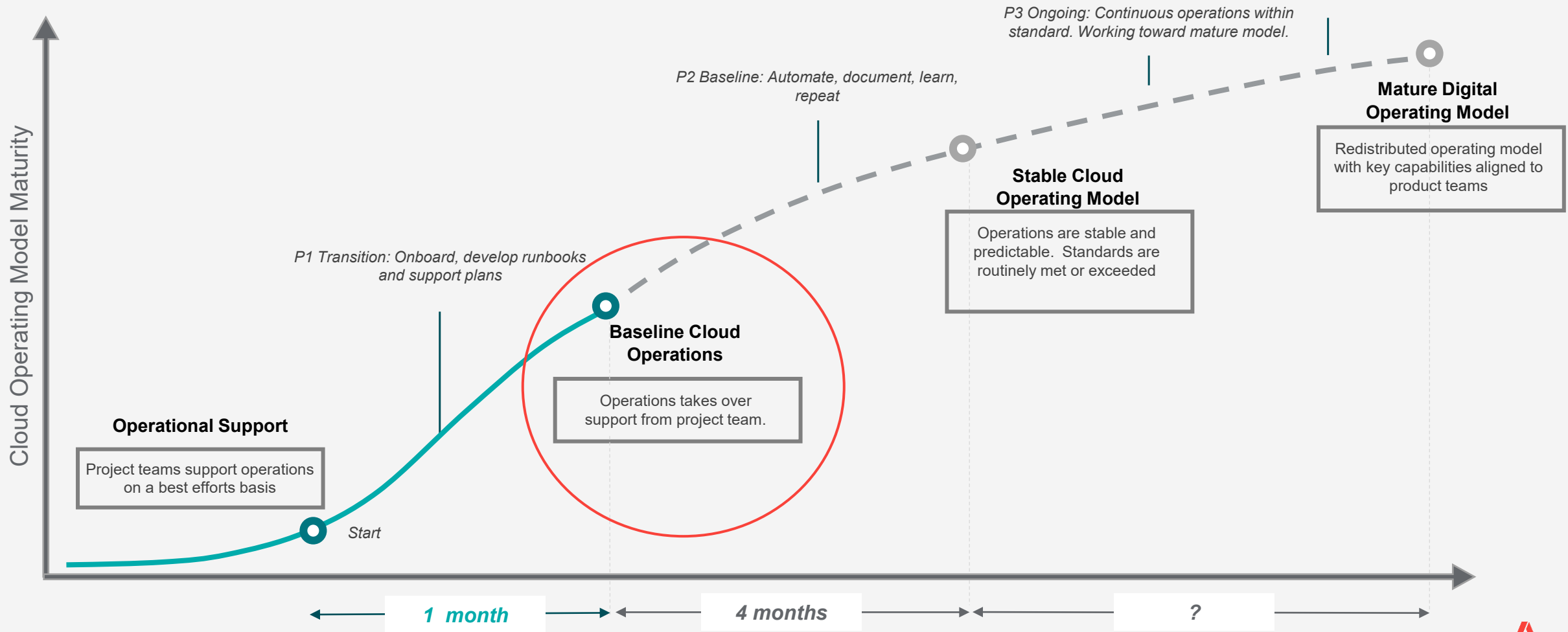

./ADA STRA

Adastra Azure Sample Designs



Tenant Design

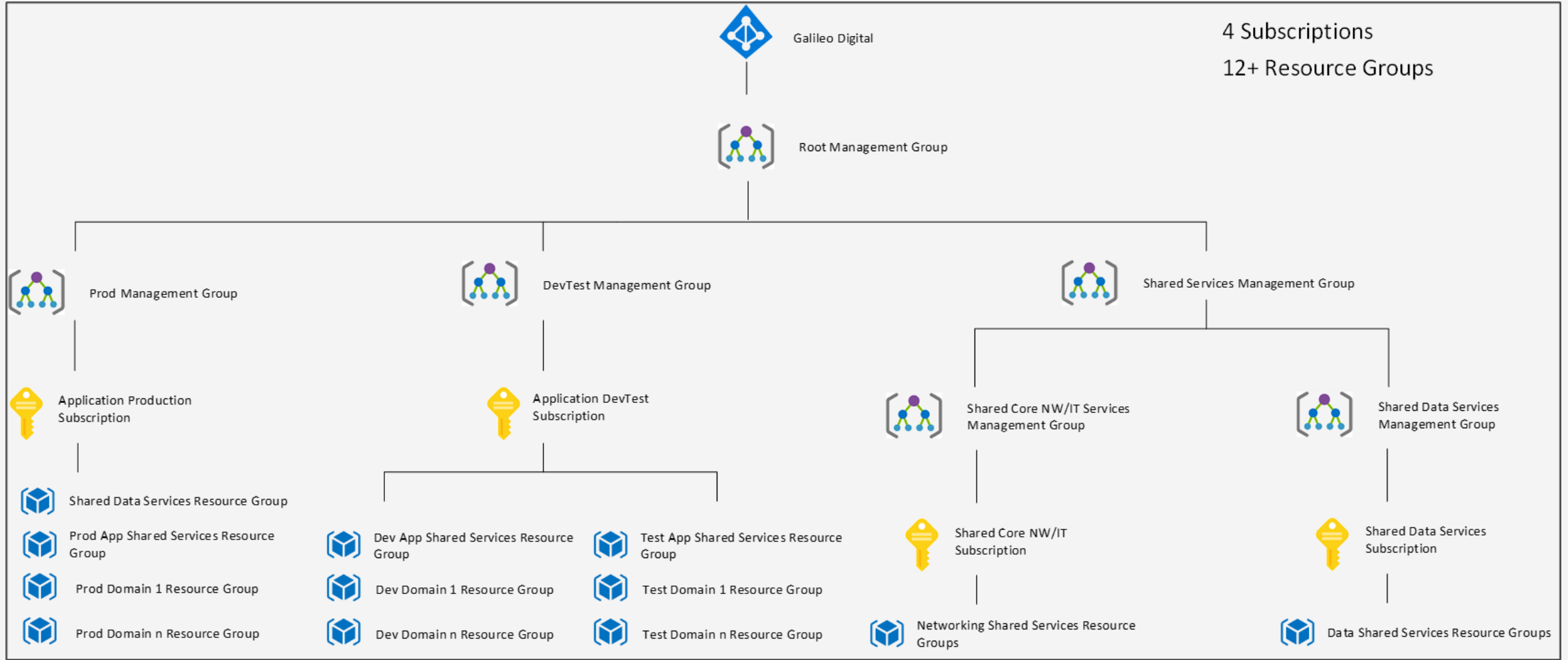

Network Architecture

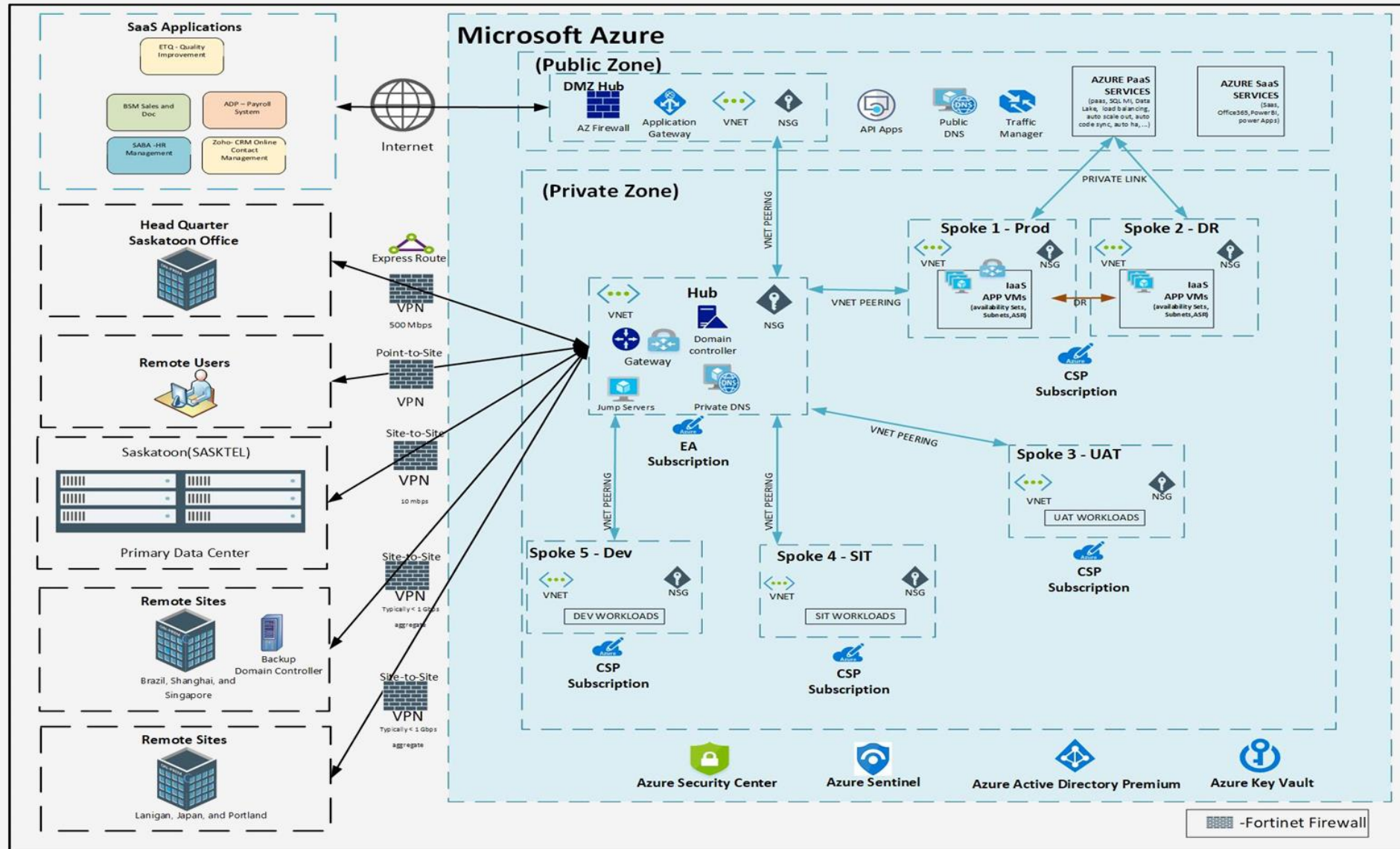

Application Architecture

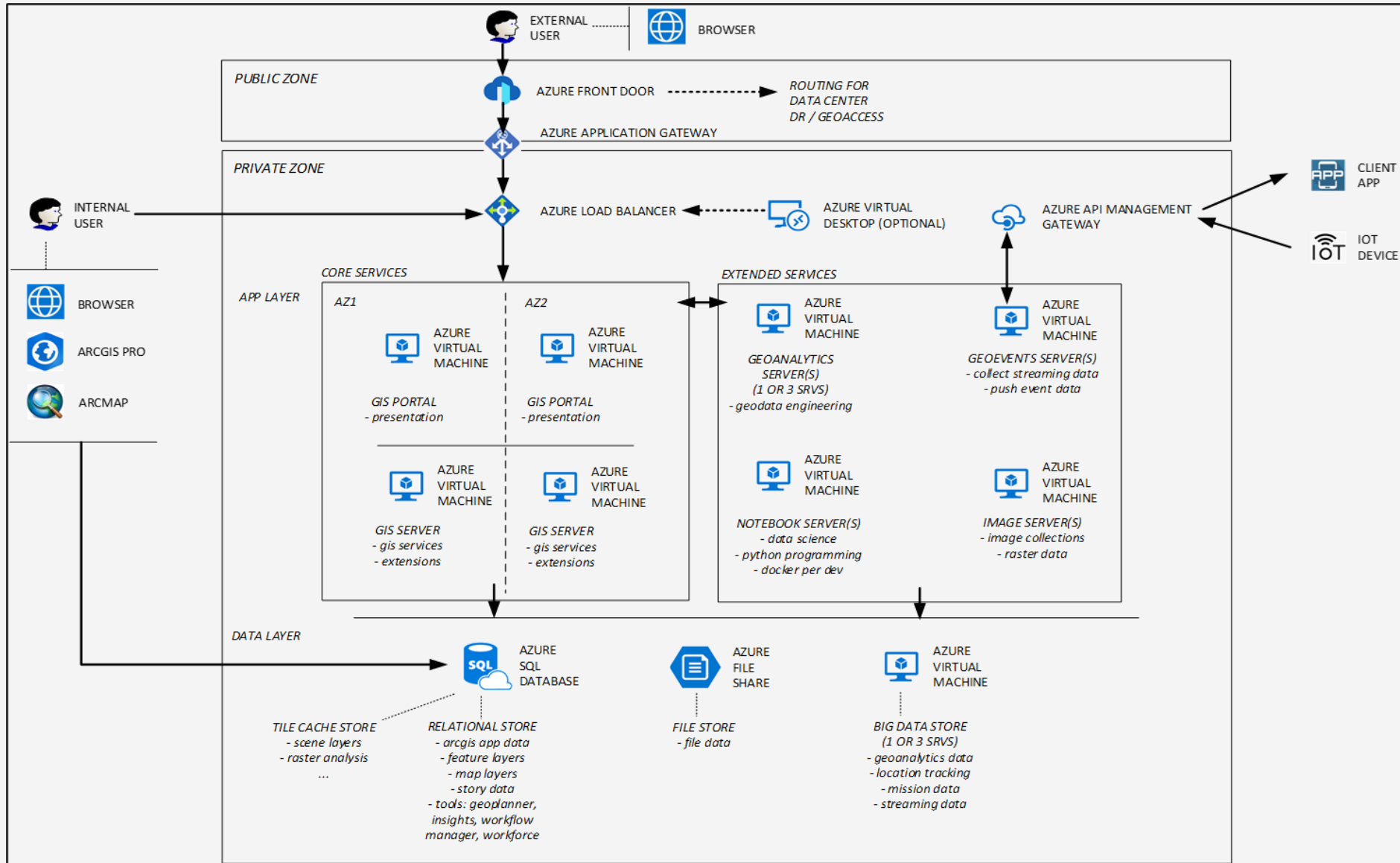

Data Hub Architecture

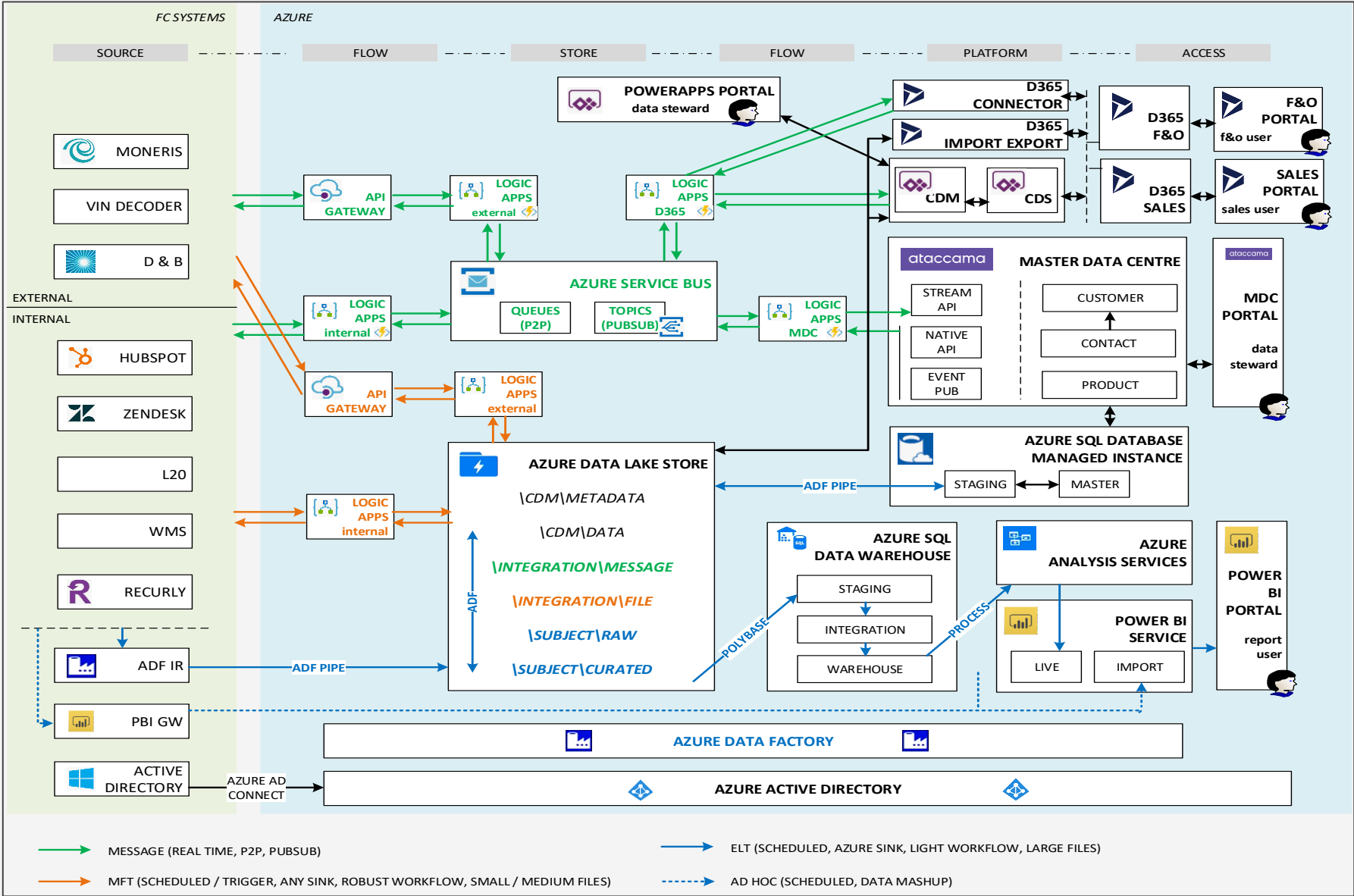

PII Data Security

Power BI Data Encryption Pattern (B)

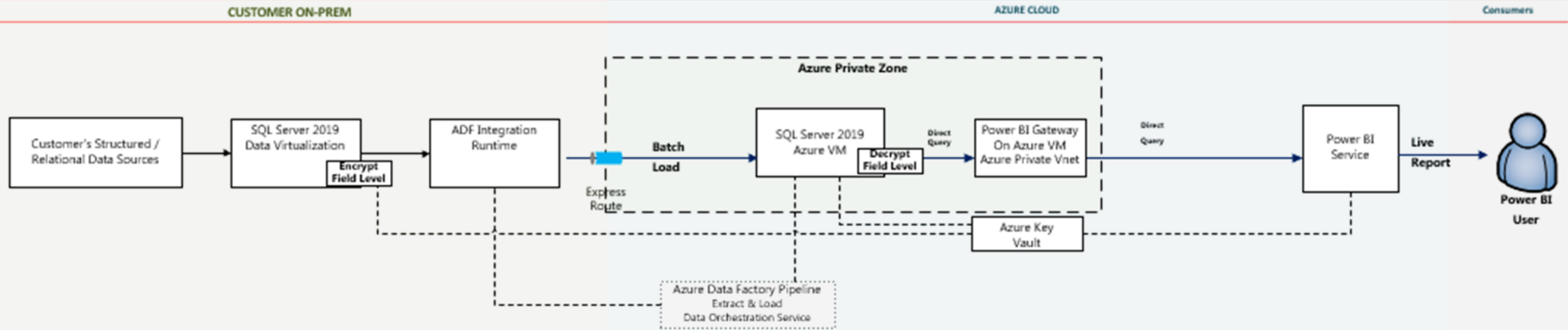

Data Encryption in Transit

TLS 1.2, MS-TDS, RSA-based 2,048-bit, using Microsoft keys

Data Encryption in Rest

Microsoft SQL Server TDE (Transparent Data Encryption) using customer managed keys
Power BI Premium Capacity Storage Encryption using customer managed keys

Field Level Data Encryption (PII/PCI Fields)

SQL Crypto Functions Encryption using customer managed keys

Key Management

Azure Key Vault Service

Key Management
Secret Management
Certificate Management
Hardware Security Module
(FIPS 140-2 Level 2 validated HSMs)

Global Deployment thru Devops

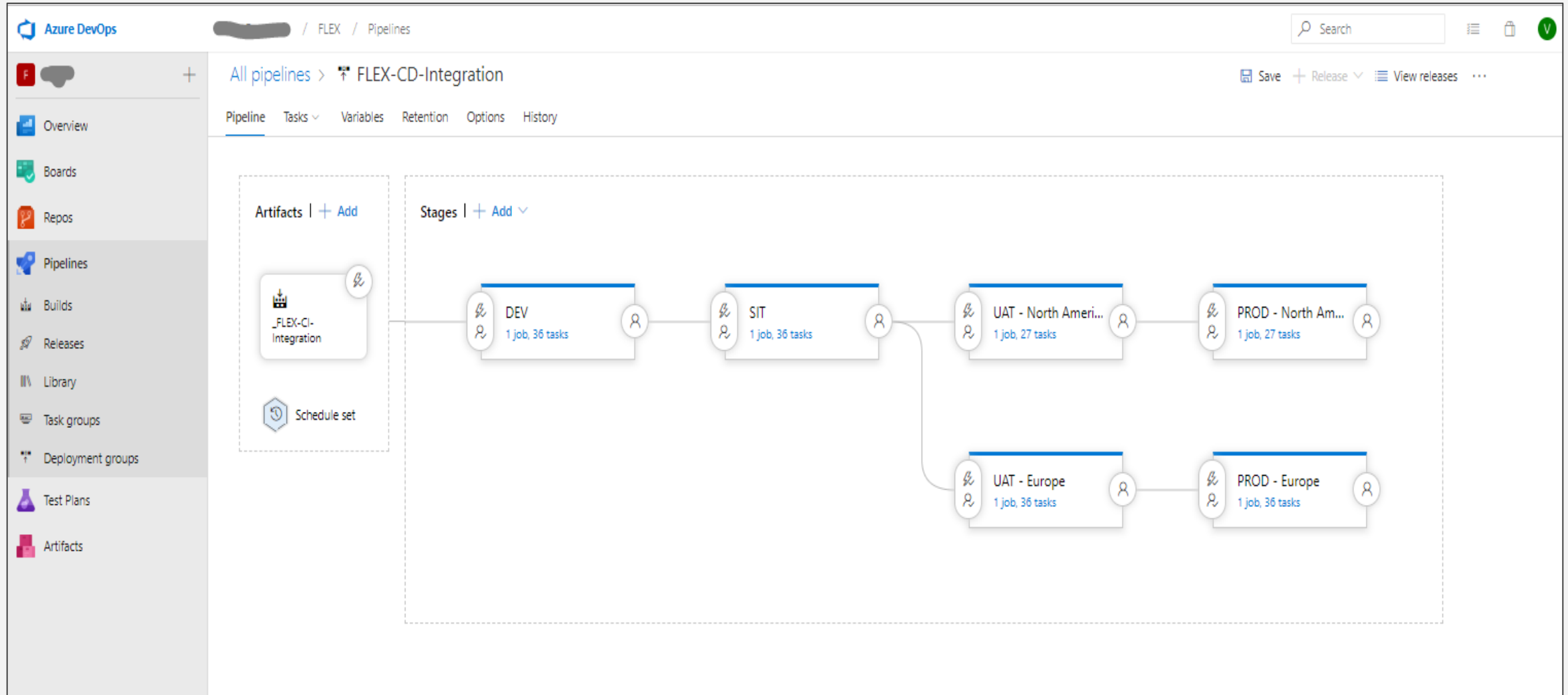

ADA STRA

Next Steps



Adastra / Microsoft Collaborative Team Structure

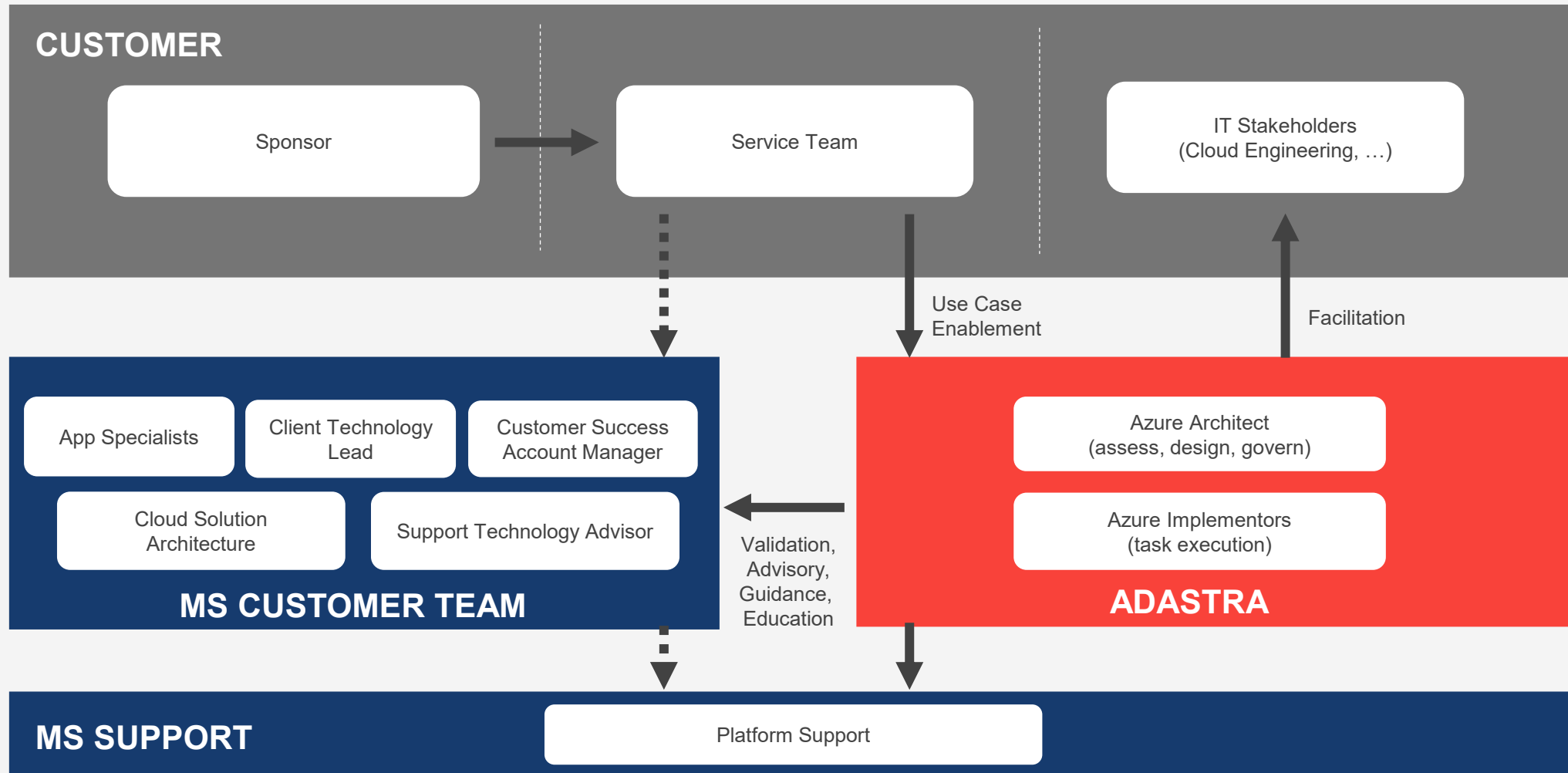

Azure Modernization Assessment



- North star / purpose playback
- High level architecture
- Estimated Azure run cost
- Implementation plan
- Implementation costs

Modernization Proposal

- Cloud modernization goals / outcomes
- Current state application services / architecture / systems
- Current state network architecture / data center design
- Future state service growth / global deployment goals
- Cloud architecture and service requirements

Assessment Workshops

Post workshops, Adastra will deliver assessment outcomes within 10 business days.

- 1 x Azure Architect
- **Cost: \$15k**

Pricing and Resources

Why Aداstra?

Adastra's deep experience with Devops standardizes and accelerates global deployment of services.

Adastra's global delivery team enables 24 / 7 support and economies of scale for our customers.

Adastra's WAgile approach ensures the right foundation, while enabling incremental value post foundation.

Adastra has implemented successful, proven Azure modernization solutions at >130 organizations.

Adastra is ranked as the top Microsoft app / data partner in Canada, and is a Microsoft global finalist.

Adastra's team of 250 certified Azure modernization specialists have deep experience realizing Azure customer success.

Adastra maintains strategic, long term partnerships with our customers. We are invested in our customers long term success.

As a 25 year old global organization, Aداstra is the right strategic partner to work with; Delloite's Top 50 Managed Companies status.

Adastra delivers the complete solution life cycle for our customers; discovery, design, plan, implement, release, support.

Thank You!



adastracorp.com



hello@adastragr.com

